

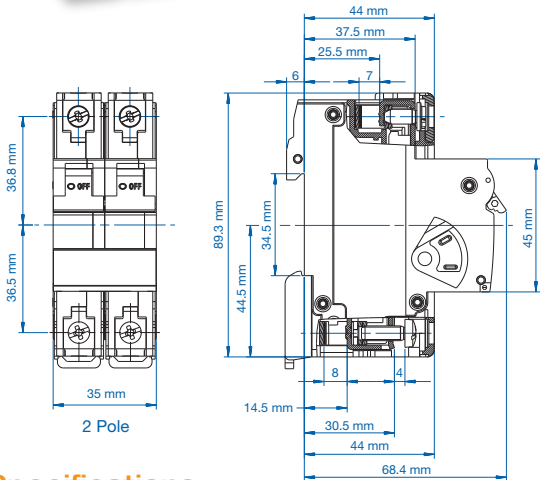

2 POLE Standard Pack 6



Rated Current (I _n)	Type/ Cat. No.	Approvals
0.3A	2C03UM	UL, SF, D'E
0.5A	2C05UM	UL, SF, D'E
0.75A	2C075UM	UL, SF, D'E
1.0A	2C1UM	UL, SF, D'E
1.6A	2C1.6UM	UL, SF, D'E
2.0A	2C2UM	UL, SF, D'E
2.5A	2C2.5UM	UL, SF, D'E
3.0A	2C3UM	UL, SF, D'E
3.5A	2C3.5UM	UL, SF, D'E
4.0A	2C4UM	UL, SF, D'E
5.0A	2C5UM	UL, SF, D'E
6.0A	2C6UM	UL, SF, D'E
8.0A	2C8UM	UL, SF, D'E
10A	2C10UM	UL, SF, D'E
13A	2C13UM	UL, SF, D'E
15A	2C15UM	UL, SF, D'E
16A	2C16UM	UL, SF, D'E
20A	2C20UM	UL, SF, D'E
25A	2C25UM	UL, SF, D'E
30A	2C30UM	UL, SF, D'E
32A	2C32UM	UL, SF, D'E
40A	2C40UM	UL, SF, D'E
50A	2C50UM	UL, SF, D'E
60A	2C60UM	UL, SF, D'E
63A	2C63UM	UL, SF, D'E

Weight (per piece)

0.3A - 32A:	33A - 63A:
0.240 - 0.282 kg	0.266 - 0.316 kg
0.529 - 0.622 lb	0.586 - 0.697 lb

C Trip Characteristic

I_n = 0.3A - 10A rated current

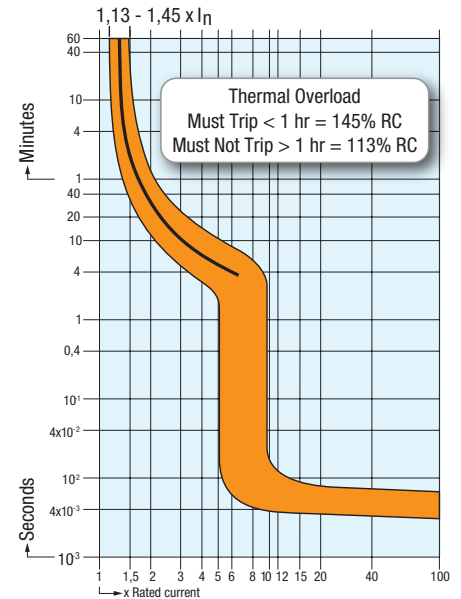

Specifications

Voltage Rating	480Y/277V AC 0.3-25A: 1 pole - 42V DC; 2 Pole - 80V DC 30-60A: 1 pole - 24V DC; 2 Pole - 60V DC
Short Circuit Withstand Rating (UL/CSA - Ratings)	0.3-60A (RC): 10kA with UL-listed RK5 back-up fuse or MCCB
Group Short Circuit Withstand Rating (UL/CSA - Ratings)	0.3-10A (RC): 10kA; 13-60A (RC): 5kA no branch circuit protection required
Interrupting Capacity (VDE - Ratings)	0.3-63A (RC): 10kA
Calibration Temperature	40°C (104°F)
Operating Temperature	-25°C to 70°C (-13°F to 158°F)
Storage Temperature	-40°C to 70°C (-40°F to 158°F)
Terminal Size Acceptability	Top: 18-3 AWG; Bottom: 18-2 AWG
Terminal Torque	2 Nm (17.7 lb.in.) / 2.5 Nm (22.2 lb.in.)
Vibration Resistance	> 15g according to DIN EN 60069-2-59 during a load with 1.05 x I _N
Resistance to mechanical shocks	25g @ 11ms
Terminal Protection Degree	IP20
Mounting Orientation	In any plane

Short Circuit Withstand Ratings for DSL8 Manual Motor Controller

Trip Curve	Amp Range	Backup Protection		
		UL-Listed RK5-Fuse up to 10kA	UL-Listed MCCB up to 10kA	No BCP Required up to:
all	0.3 - 10A	4xRC* min 15A, max 70A	4xRC* min 15A, max 70A	10kA
all	12 - 30/32A	4xRC* max 125A	4xRC* max 125A	5kA
all	40 - 50A	4xRC* max 200A	4xRC* max 200A	5kA
all	60 / 63A	4xRC* max 250A	4xRC* max 250A	5kA

*up to nearest rated current

C Trip Characteristic

I_n = 13A - 60A rated current

