

Relays basic information

Function of the Relay	2
Main Parts of the Relay	2
Types of Relays	3
Terminology	7
Coil Operating Voltage Range	8
Coils - Overvoltage Protection	8
Switching Section: Main Diagrams and Mechanical Solutions	10
Contacts and Shapes of Contacts	11
Contact Materials	13
Electric Life of Relays	16
Switching at Alternating and Direct Current	17
Arc Breaking	17
Suppressing Circuits	18
Special Loads	19
Switching Time and Contact Bounce	20
Sinusoidal Vibrations	21
Current Surges	21
Hermetic Relays - Soldering and Cleaning	22
Types of Relay Terminals	24
International Standards	25

According to USASI (United States of America Standards Institute) a relay may be as an electrically controlled device which opens and closes an electrical circuit in order to the operation of other devices in the same or another circuit. Relays are a element in the contemporary industrial processes.



Dozens of milliards of relays operate nowadays int he world as an interface between control circuits and electrical load. The technological development has brought miniaturization of mono-and bi-stable relays which need a low or even no supply voltage to carry a high power through the contacts.



Function of the relay

The relay performs two crucial tasks:

1. Galvanic separation (isolation) of the control section and switching section.
2. Switching of high-power loads with high voltage and/or current of high intensity at low energy consumption (low voltage / low current intensity) even at low electrical signals.

There are numerous applications of relays. Whenever satisfactory operation is needed in electronic and electro-mechanical conditions, a relay is necessary, e.g. for control equipment, time relays, temperature control, etc.

Main parts of the relay

The electromechanical relay consists of an electromagnetic switch and an electric one.

The former is the control section, and the latter is the switching section which is directly connected to the electrical load.

The electromagnet transforms the electrical current into a magnetic stream that generates the force which moves the switching part.

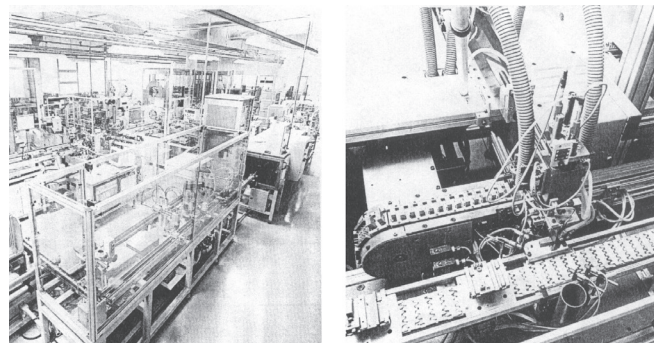

Electromagnet

Fig. 1. Classic electromagnet unit

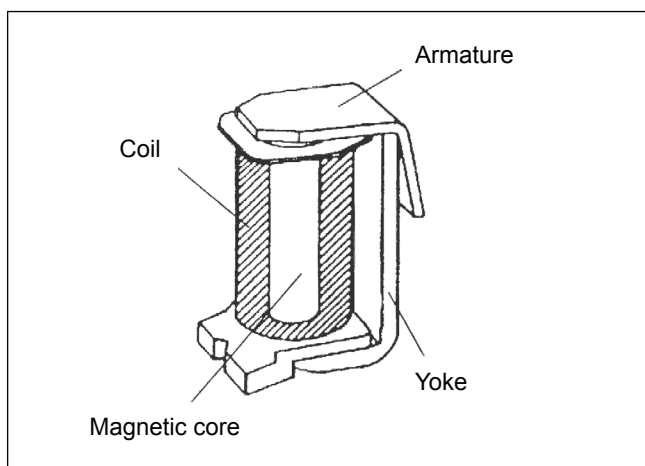

Fig. 1 shows a classic electromagnet unit which consists of four basic parts:

The coil which consists of one or more windings of a copper wire that is usually wound around a spool made of insulating material.

Ferromagnetic core

Ferromagnetic yoke

Movable ferromagnetic armature

Fig. 2. Classic design of a relay

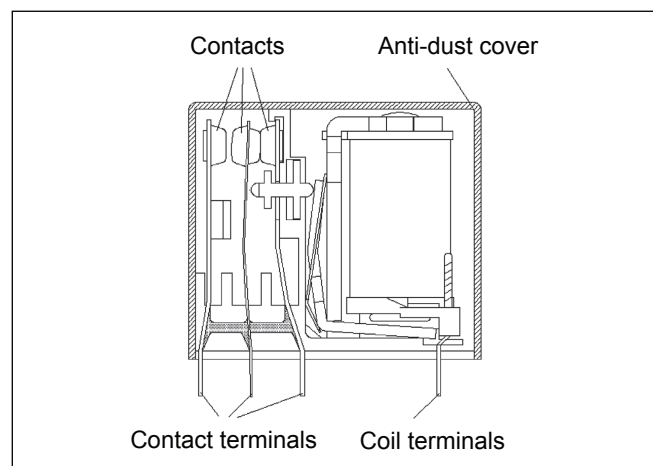

Additional parts:

- Fixed and movable contact springs
- Contacts
- Pusher
- Mounting terminals and coil terminals
- Contact plate
- Anti-dust cover

Switching section

A classic arrangement of the switching section refers to a diagram of one changeover contact. It has been used in the explanation below as it is a basic diagram referred to by all other diagrams.

Fig. 3 shows the switching section of a relay with one changeover contact.

The **figure** presents the following parts:

- **fixed** normally closed (NC) contact unit,
- movable contact unit
- fixed normally open (NO) contact unit
- pusher,
- contact plate
- soldering terminals

Fig. 3. Switching section of a relay

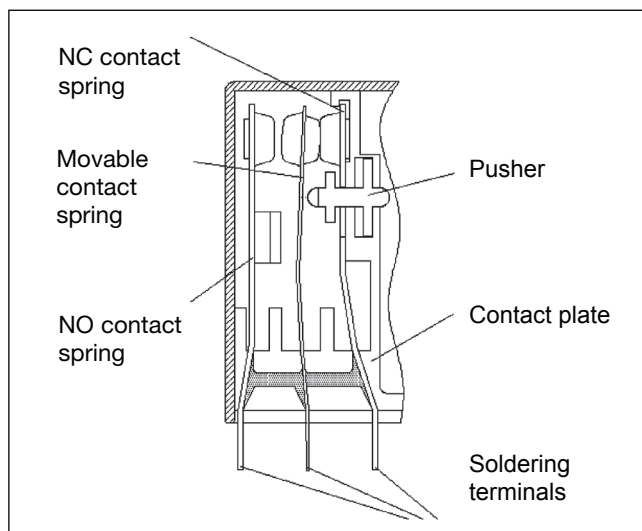

Types of relays

There are two kinds of the device, i.e. electromechanical relay and solid-state relay (SSR).

Electromagnetic and solid-state (SSR) relays

Operation of solid-state relays is very similar to that of electromechanical relays - it consists in switching the load circuit, which is controlled with a low voltage signal of an insulated input circuit. In an **electromagnetic relay**, the electromagnetic force which moves the yoke and causes switching of the contacts

is generated when input voltage is applied to the coil. When the supply voltage is interrupted, the return spring pushes the contacts away from each other, i.e. opens the contacts and disconnects the power circuit.

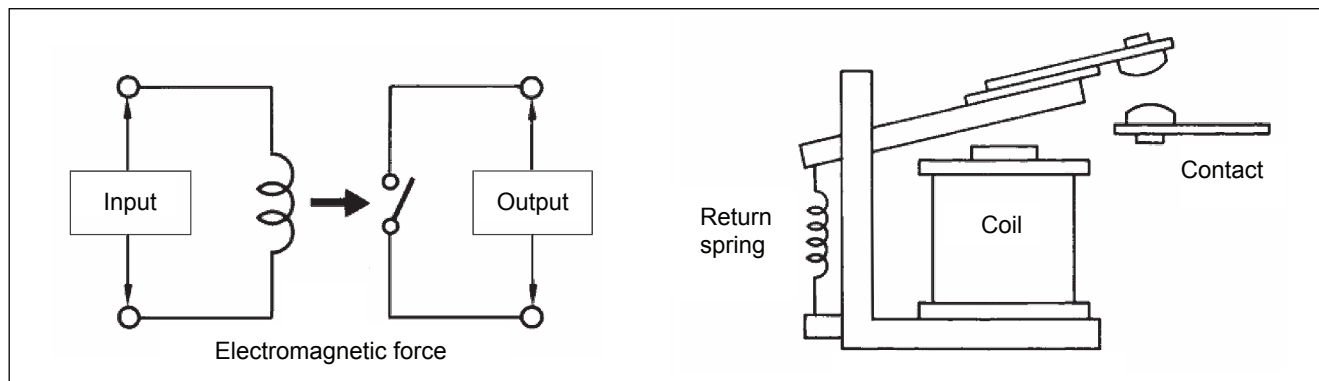

Solid-state relays use an opto-isolator to disconnect the input and output circuits. The opto-isolator changes electrical signal to optical ones and transfers them through the distance which is a galvanic insulation between the input and output sections. SSR's are electronic devices which do not have any movable parts, and the switching elements are thyristors, triacs or transistors.

The input current flows through a light-emitting diode which is usually made of gallium arsenide and it emits radiation in infrared. The diode illuminates the photovoltaic cell which generates voltage to control the output element.

In the opto-isolator, a photodiode, photo-transistor or a photo-thyristor may be the photodetector.

The opto-isolator carries both direct-current signals and alternating-current ones (analog and digital signals).

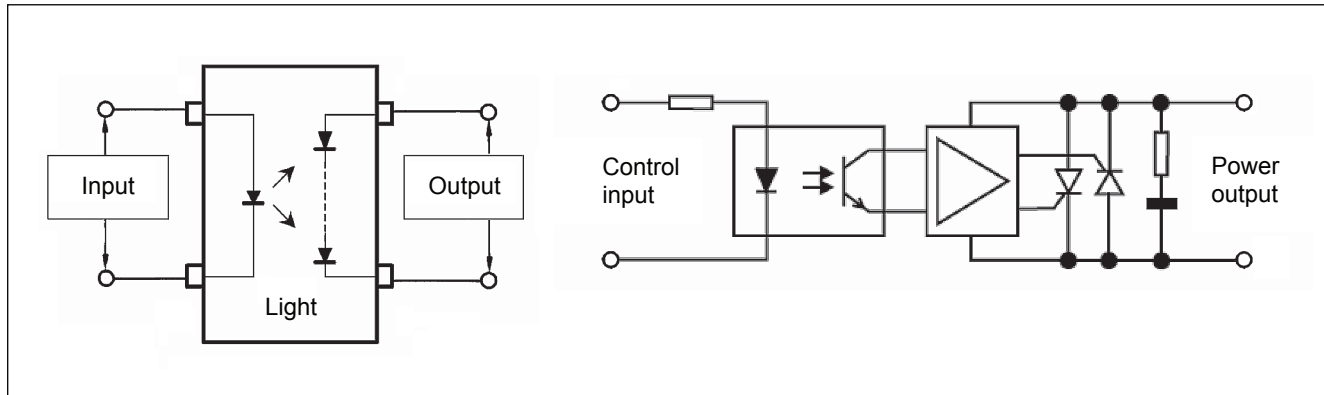

Advantages of solid-state relays:

1. Absence of movable parts due to which their operation is completely noiseless, which is of high importance in dwelling rooms, etc.
2. There is no electric arc in the course of switching operation which takes place inside the semiconductor material, the function of making high starting currents, long life and reliable operation.
3. High resistance to shock, vibrations and environmental pollution.
4. No electromagnetic interference owing to completely electronic control.
5. High operation speed and high operation frequency.
6. Low power necessary to control the relay.

Disadvantages:

1. High resistance is switching on state, which causes generation of heat and necessity to use radiators.
2. Considerable voltage drop on the interface (1-1,6V).
3. Sensitivity to overvoltage, necessity to use a varistor or RC circuit.

As compared to solid-state relays, electromagnetic relays bear the stamp of negligible small voltage drop (the contact resistance in switching state is on the average about 10 mΩ), and zero leakage current, they are also highly resistant to overvoltage. Due to the mechanical system of contacts and their wear and tear, their life is definitely shorter, and the response time is long and prevents the use of higher operation frequency. The capability of switching surge currents is also considerably smaller.

SSR's provide the possibility of switching at "zero" for resistive load and, then the voltage on the load increases gradually, which, in some cases, e.g. an electric bulb, affects significantly the period of life. This limits surge currents too.

For inductive loads, relays which switch at maximum voltage are useful - conduction occurs at supply voltage peak value, then the surge current is minimized.

Among the basic types of electromechanical relays, monostable and bistable relays should be considered separately.

Mono- and bistable relays

Monostable relays

A monostable relay is an electrical relay which changes its status due to a supply value of the appropriate parameters and returns to the previous status when the parameter ceases or changes.

Bistable relays

A bistable relay changes its status as affected by the appropriate supply value of the appropriate parameters and remains in the changed state even after the value has ceased. Another application of the appropriate supply value is necessary for the relay to change its status again and return to the previous state.

Further classification of relays may be based upon the functions they perform, e.g. all-or-nothing relays, step relays, latching relays, polarized relays, reed relays.

All-or-nothing and step relays

All-or-nothing relays

The term identifies the relays designed for operation at the value that is:

- higher than the make value, or
- lower than the return value.

This type of relays must be supplied by a particular range of voltage (or current).

They may be energized by supply or disconnection of voltage (or current) within a given range.

Step relays

The relays have two or more rotational positions, and they move from one step to another in consecutive operations with the use of energizing pulse. They usually move the contacts with the use of cams.

Latching relays

The latching relay is a non-polarized bistable relay. It changes its state at the supply value and remains in the position after the value has ceased. In order to change the state of the relay again, another actuation is necessary. The crucial part of the latching relay is the core made of special magnetic iron which remains magnetized ever after a voltage pulse has been applied. The core consists of a nickel base with aluminum, titanium or niobium added (55-85% Co, 10-12% Ni).

Function

Energizing condition: OFF state

As the wiring is supplied with a voltage pulse of direct current V_1 (selected from the recommended supply voltage range) for the duration of t_i , the electromagnetic field grows immediately, the core becomes magnetized and the relay is energized (the normally open contact closes). When the pulse declines, the relay remains in the ON state owing to the permanently magnetized core (Fig. 4).

Fig. 4. Latching relay, electrical circuit

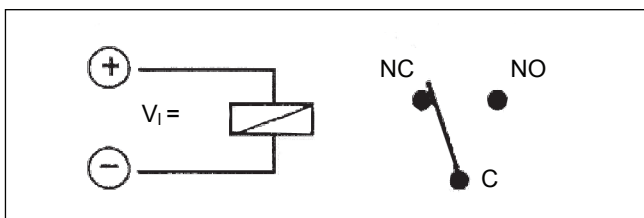

Thus, the magnetic polarization of the relay depends on the polarity of the supply voltage. The relay switches to the OFF state on supply of the voltage of the opposite polarity which changes the magnetic polarization of the core. The sole change of the supply polarity will not cause the release of the relay. This requires a change of the polarity, and the value of the energy supply must be within the range of the actuation (energizing) values.

The circuit applied

There are two different types of the latching relays:

- **single winding** latching relays with the external release resistance to limit the current intensity (Fig. 5).

Fig. 5. Circuits with single winding latching relays

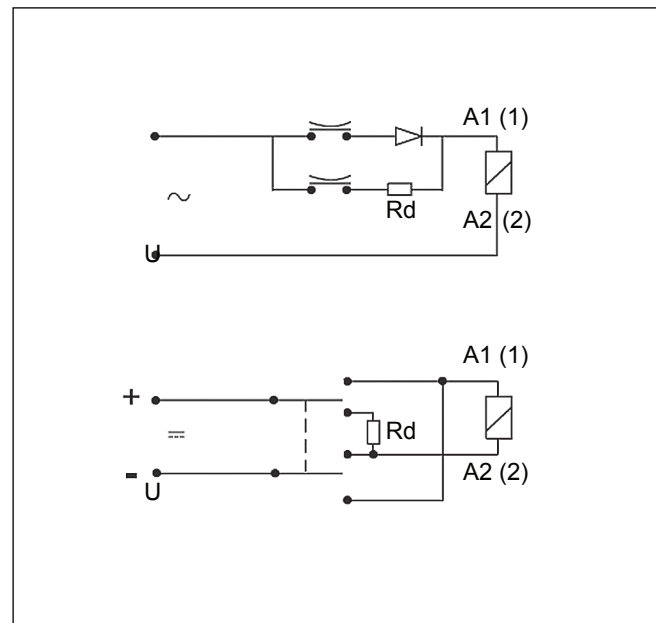

- latching relays with **two windings** and two different voltage ranges for ON / OFF operation (Fig. 6).

It is important to bear in mind that for the appropriate operation the relays require a **minimum pulse** of 10 ms. In order to avoid overheating, the maximum time of supply is usually limited, too. The aforementioned relays may also be supplied with alternating voltage owing to the external diode which rectifies the alternating current to the pulses of minimum duration of 10 ms (half of the period). The applications of latching relays are the same as the applications of the normal version relays.

Fig. 6. Circuits with two winding latching relay

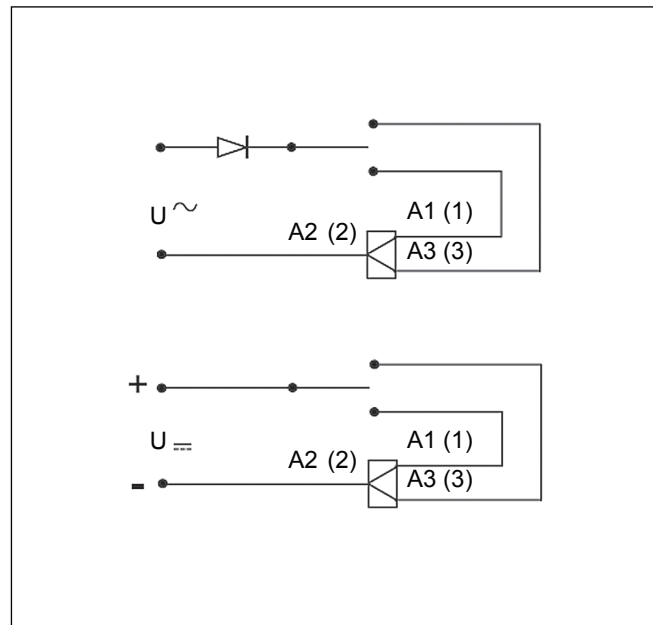

Polarized relays

Polarized relay is a relay with permanent magnet which provides additional magnetic force that reduces the energy consumption. The magnetic field required for pulling the armature is partly generated by the coil and partly by the magnet.

The magnetic streams overlap. The supply value must be of the appropriate polarity, i.e. the same as the polarity of the magnet. There are mono- and bistable versions of these relays.

Reed relays

The remarkable advantage of the reed relays is that they are hermetically sealed and, thus, resistant to atmospheric corrosion. They are very fast (10 to 20 times faster than electromechanical relays) and at the range of the rated contact load they offer highly reliable switching operations, and extremely long life. The fundamental part of a reed relay is a hermetic glass tube, commonly called the magnetic (reed) contact.

The magnetic (reed) contact consists of two flat, ferromagnetic lap contacts of the reed relay separated by a small air-clearance, hermetically closed in a glass tube. The contacts of the reed relay are fixed to the ends of the glass tube and, thus, they serve as supports. If the free ends of the reed contacts are exposed to the magnetic field, the stream in the clearance between the reed contacts will make them cooperate.

When the magnetic field ceases, the reed contacts will part from each other as a result of the stress of the spring placed in the contacts. This way, the contacts provide an operating magnetic clearance, and they close and open the electrical circuit.

Fig. 7. Hermetic contact

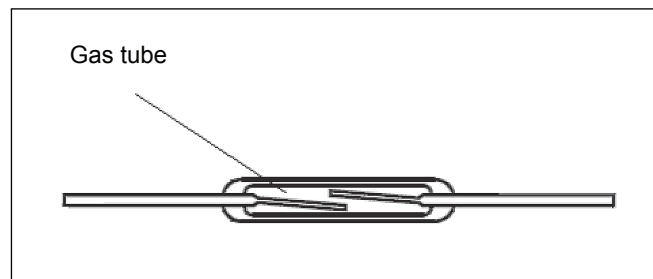

Terminology

Actuation condition - in case of a monostable relay: specific status of a relay while it is supplied with a given supply value which has been energized; in case of a bistable relay: a status opposite to rest condition indicated by the manufacturer.

Actuation - change from rest condition to actuation condition.

Return - in case of a monostable relay: change from actuation condition to rest condition.

Reset - in case of a bistable relay: change from actuation condition to rest condition.

Constant operation - operation during which a relay remains actuated for the time long enough to reach heat balance.

Cycle operation - operation during which a relay performs several make cycles, where intervals of actuation and absence of actuation are defined; actuation time of the relay is such that heat balance of the relay is impossible to be achieved.

Coil thermal resistance - the ratio of increment of the coil temperature and the input power, measured after the time sufficient for achieving heat balance.

Make voltage - the coil voltage value at which the relay is actuated.

Return voltage - the coil voltage value at which a monostable relay returns to the previous condition.

Reset voltage - the coil voltage value at which a bistable relay is reset.

Normally open contact - a contact which is closed when the relay is actuated, and open when the relay does not operate.

Normally closed contact - a contact which open when the relay operates, and closed when the relay does not operate.

Changeover contact - a set of two contact circuit made of three members of which one is common for two contact circuits; when one of the circuits is open, the other is closed.

Contact gap - a gap between contacts at open contact circuit.

Making capacity - the highest value of electric current which may be connected by a contact when specific conditions are met, e.g. making voltage, number of operations, power factor, time constant.

Maximum continuous current - the maximum value of the current which may flow through a closed contact continuously in specific conditions.

Isolating air gap - the minimum distance in the air between two conductive parts or between a conductive part and exposed surface of the relay.

Isolating surface gap - the minimum distance on the surface of the isolating material between two conductive parts.

PTI - indicator of resistance to creeping current - numerical value of proof voltage expressed in Volts, which may be resisted to by the isolating material without formation of conductive tracks, defined in specific conditions of experiments.

CTI - a comparative indicator of resistance to creeping current - numerical value equal to maximum voltage expressed in Volts, which may be resisted to by the isolating material without formation of conductive tracks, defined in specific conditions of experiments.

Coil operating voltage range

The admissible operating voltage range for the coil as the function of the ambient temperature is shown in the chart for RM85 relay.

The maximum operating voltage of the coil is limited by the increase of the coil temperature caused by the heating of the winding. The increase shall not exceed the admissible temperature defined for insulation materials.

The make voltage is the minimum operating voltage of the coil. The make voltage grows along with the increase of the winding temperature. Since the resistance of the copper wire changes by 0,4% per Centigrade, the growth of the coil temperature caused by a higher ambient temperature or by contact load results in the drop of the coil current and, thus, the increase of the voltage required for the relay electromagnet to operate.

Fig. 8. Coil operating range - DC

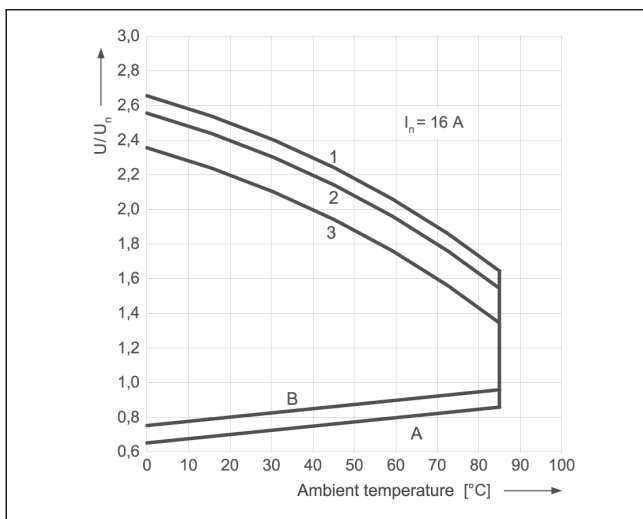

A - relations between make voltage and ambient temperature at no load on contacts. Coil temperature and ambient temperature are equal before coil energizing. Make voltage is not higher than the value read on Y axis (multiplication of rated voltage).

B - relations between make voltage and ambient temperature after initial coil heating up with $1,1 U_n$, at continues load of I_n on contacts. Make voltage is not higher than the value read on Y axis (multiplication of rated voltage).

1, 2, 3 - values on Y axis represent allowed overvoltage on coil at certain ambient temperature and contact load:

1 - no load

2 - 50% of rated load

3 - rated load

Coils - overvoltage protection

While using electromagnetic relays in electric circuits, it should be borne in mind that coils are the source of significant overvoltage which may disturb the operation of the equipment in which electromagnetic relays are applied. Furthermore, due to overvoltage the equipment in which electromagnetic relays are used may not meet the requirements of electromagnetic compatibility.

Relay coils have high inductance during operation, which causes a rapid increase of the coil voltage on switching off. Such a situation occurs in both DC and AC voltage coils. If, for example, the coil is switched off by a transistor, the latter may be damaged. Moreover, such pulse disturbances may affect negatively the nearby electronic systems.

Fig. 9. DC coil voltage during switching off

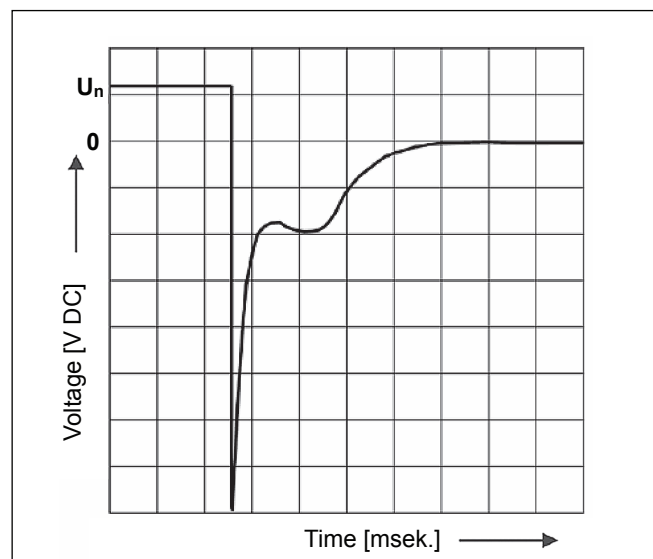
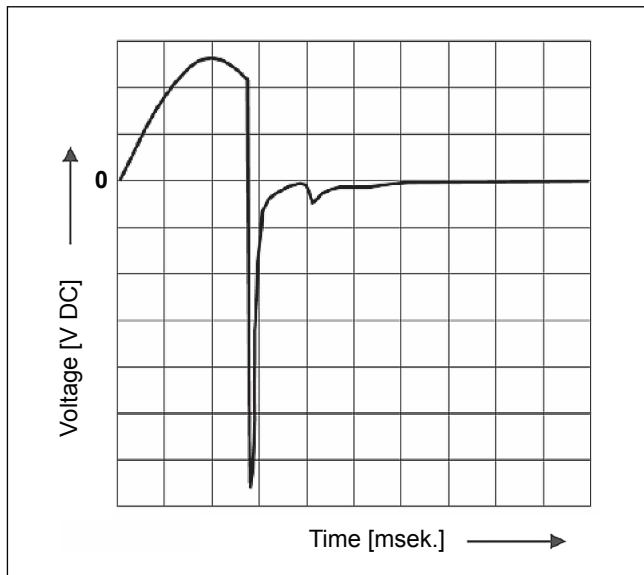

Fig. 10. AC coil voltage during switching off



For coils supplied with DC voltage, the best and simplest solution of the problem is a parallel connection of a standard rectifying diode to the coil terminals. During the current flow, the diode has a reversed bias due to the voltage drop on the coil. On switching off the coil voltage, the diode starts conducting which results in the coil voltage increase merely by the voltage drop on the conducting diode. Designers of electronic systems with electromagnetic relays practically always use suppressing diodes connected in parallel to the relay coil. The 1N4007 diode is a perfect solution in most of such cases. Diodes remove overvoltage extremely efficiently, they are a cost-effective and reliable way of suppressing coil self-induction voltage, which does not involve complicated calculations. The only weak point of the diode system is a remarkable (threefold) increase of the relay release time. The release time may be reduced by connecting an additional resistor in serial to the diode in which case, however, the overvoltage value grows while the coil is being switched off.

The **diode protection** cannot obviously be used with AC coil relays. In such cases, two types of protection are commonly used, i.e.:

- varistor protection, and
- R-C two-terminal network protection

Metal-oxide **varistors** have similar current-voltage characteristics to that of a bidirectional Zener diode. When the voltage between the varistor terminals exceeds a given limit value, it starts conducting, and, thus, it shunts the inductive load (the relay coil) with its differential resistance. The maximum overvoltage value on switching off depends on the limit voltage of the varistor.

Furthermore, when the varistor is supplied from the mains, the varistor protects also the relay coil from being damaged by the voltage pulses that occur in the mains. The varistor protection may be also applied in DC coil relays. However, the overvoltage values on switching off are much higher than in the case of protection with the use of a suppressing diode.

Another way to limit the overvoltage values during coil switching off is a parallel connection of an **R-C two-terminal network** to the coil. The network limits the overvoltage well, it is inexpensive, and it only slightly increases the relay release time.

No ceramic **capacitors** should be used whereas it is recommended to use foil capacitors. On selection of a **resistor**, it should be taken into consideration that quite a large amount of power dissipates on it during the transition process and, thus, the resistor's power shall not be less than 0,5 W.

Relpol S.A. offers both relays with integrated **overvoltage protection elements** (diodes or varistors) and ready-to-use **overvoltage protection modules** to be mounted in plug-in sockets.

R2N, R3N and R4N relays with DC coils are also in the version with suppressing diode mounted inside the relay. However, varistors are not mounted inside these relays. Ready-to-use overvoltage protection modules of M series may be used with the relays and then the modules are mounted in GZT., GZM. and GZMB. series plug-in sockets. Modules with a diode (DC coils) or with a varistor (DC or AC/DC coils) are available.

R15 relays are manufactured solely with the overvoltage protection element integrated, i.e. with the suppressing diodes for DC coils (two-, three-, and four-pole versions) and with varistors for AC coils (two-, and three-pole versions). In the case of a suppressing diode as the overvoltage protection element, the coil supply polarity must be as follows: A1 terminal "+", A2 terminal "-". note: the specified polarity does not refer to the relays R15 4 CO – four-pole for which the coil supply polarity must be as follows: A1 terminal "-", A2 terminal "+".

Ordering codes of the overvoltage protection elements integrated in the relays (as add-on equipment) are as follows:

- D** - suppressing diode
- V** - varistor

While using an overvoltage protection element, the user may be assured that the overvoltage that occurs on switching the coil off will not affect negatively the coil control circuits or any other electric and electronic circuits.

Switching section: main diagrams and mechanical solutions

There are various contact configuration diagrams related with different application requirements, i.e. normally open contacts (NO), normally closed contacts (NC) and changeover contacts. These are the basic configurations used for designing all the contact diagrams of relays. With the use of the basic contacts, many relay circuits may be built in order to apply relays successfully. The only theoretical limitations are the dimensions of relays, electromagnetic energy, switching energy and the complexity of drawings. The contact configurations available in a relay are determined by the number of poles, type of the contacts (changeover or normally open/closed), and normal position of the contacts (normally open or normally closed). In table next are listed **symbols depicting exact type of contacts**.

Contact type	Marking		
	Relpol S.A.	Zettler	USA
CO	1	C	SPDT
NO	2	A	SPST-NO
NC	3	B	SPST-NC

SP = single pole
 ST = single contact (normally open or normally closed)
 NO = normally open contact
 NC = normally closed contact
 DP = two contacts
 DT = changeover contact

Other manufacturers of relays apply also different ways of defining the configuration of contacts. They may be found in catalogs and catalog cards published by the companies.

Terminals marking

Terminals marking under Polish Standard EN 50005.

Contacts terminals are always marked numerically with two digits, where:

- the unit digit is the number of functions,
- the decimal digit is the number of sequences.

Coil terminals are always literal-numerical.

The scheme of marking of terminals of contacts and coil for a four-track relay (see below).

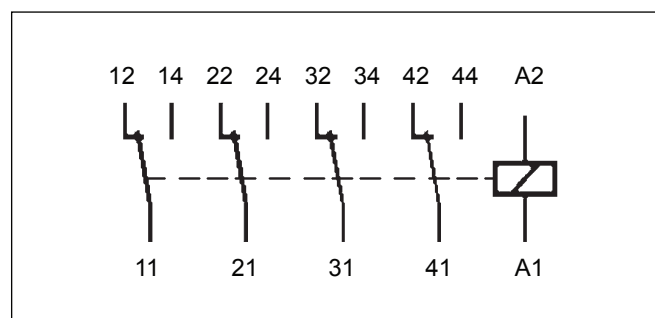
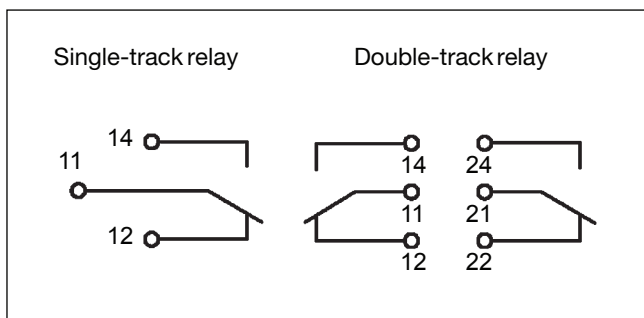
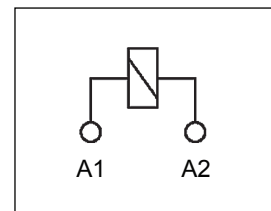

Contacts and shapes of contacts

Contact pressure

When two contacts come together to close the electrical circuit, they touch each other within the area that depends on the shape of the contacts. The force (N) with which the contacts push against each other as measured on the contact axis, divided by the area of the contact (mm²) equals the contact pressure (N/mm²). It is practically impossible to determine the real contact area as it depends also on the roughness of the contact surface. The contact pressure is determined by the contact force. In order to obtain a large contact area, the contact force must be increased so that the contact area roughness may be deformed. A low force means a few effective contact points and a small area of the contact (i.e. a high contact resistance). On the other hand, a stronger force increases the number of contact points and the total contact area (lower contact resistance). The contact force may be increased only to the limit defined by the mechanical strength of the parts and as much as it is allowed by the supply voltage sensitivity.

Manufacturers of relays use **different shapes** of contacts according to the relay designs and applications.

Fig. 11. Effect of the contact force

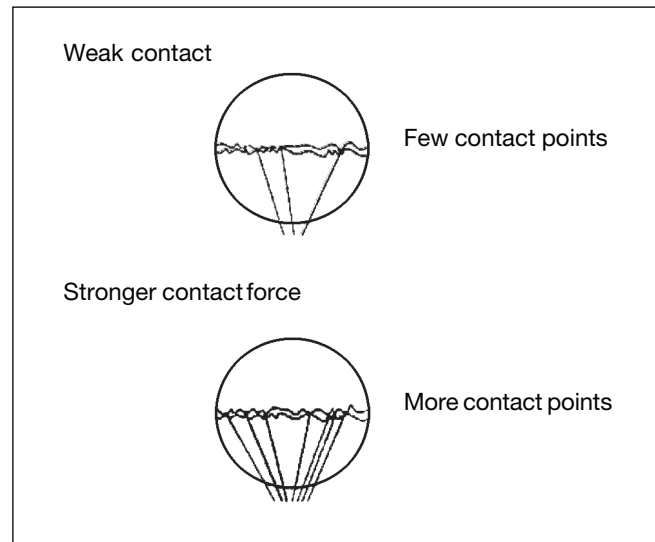
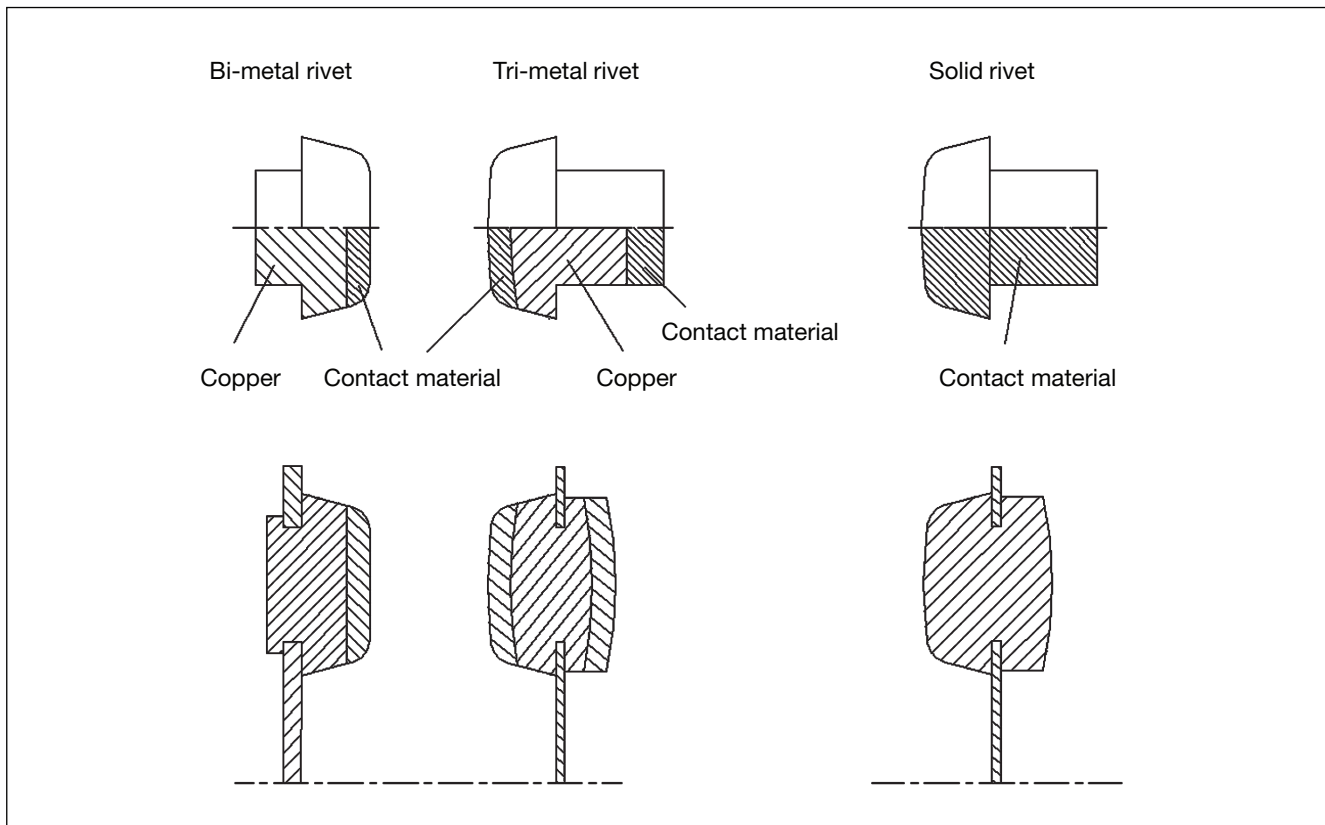

Fig. 12. Shapes of contact rivets



Cylindrical contact rivets

Cylindrical contact rivets are usually used in their bimetallic, solid or other versions, similarly to the contact parts of miniature relays owing to their optimal switching capabilities and easy assembly. Normally, the contacts are connected between the flat surface of the fixed contact and the spherical surface of the movable contact (the common contact). Principally, the common contact is a solid one whereas the fixed contacts (NC and NO, when in switching operation) are bimetallic ones (Fig. 12). The head of the central solid contact is ready to use on one side, and it is shaped during assembly on the other side. The flat-spherical connection between the contact surfaces is necessary for the reduction of the area of connection with the simultaneous increase of the contact pressure. Moreover, relative surface movement (roll) occurs then, which is useful in terms of enhanced contact performance (Fig. 13).

Fig. 13. Contact movement

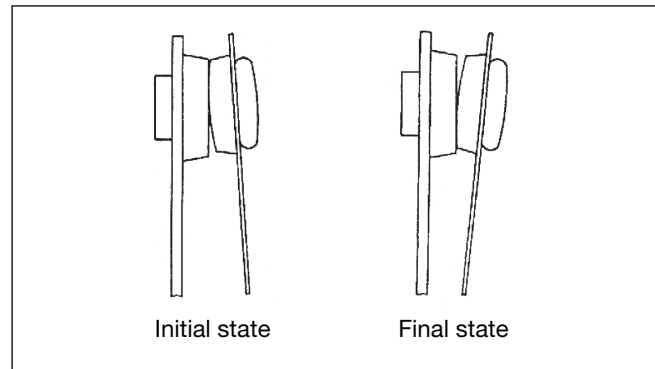

Small-profile contact

A pressed strip of metal or contact alloy is automatically welded to the spring material prior to the cutting process. During the cutting process, the spring strip is cut together with the contacts, and the contact is formed to the required shape (Fig. 14). This solution is useful as it provides avoiding a dangerous voltage drop on the spring-contact connection. This allows the appropriate selection of the contact shape.

Fig. 14. Small-profile contact

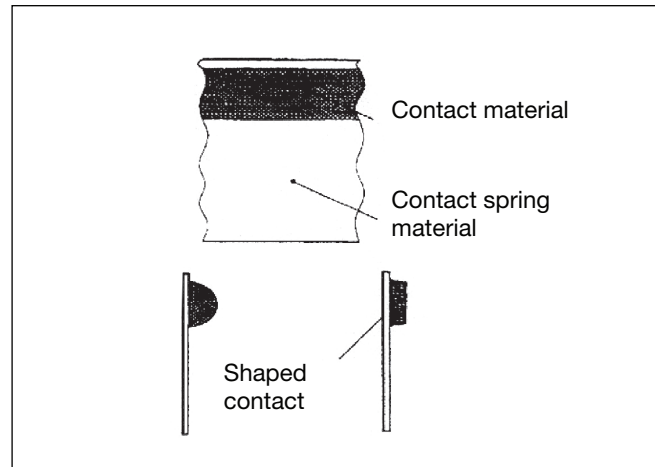

Cross contacts

While using small-profile contacts it is possible to design a contact coupling with cylindrical surfaces and perpendicular axes. This way, a limited contact area and high contact pressure may be obtained. Moreover, during switching, two contacts operate like "two knives", thus maintaining a very clean contact surface.

Fig. 15. Cross contact

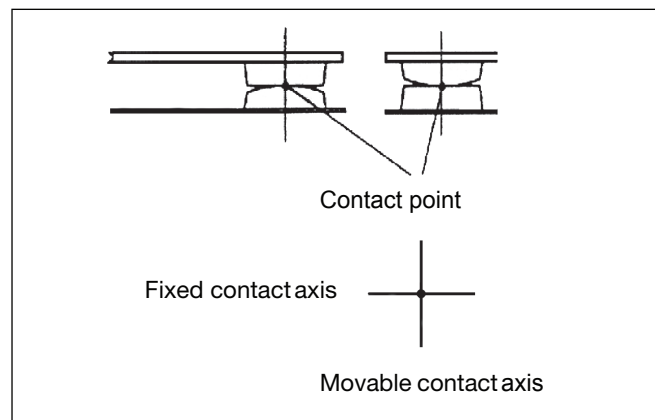

Twin contacts

For some applications (e.g. low-level signals - safety systems), in order to enhance the contact reliability, twin contacts are used. Small-profile rivets or contacts are placed one next to another on the same forked spring (springs of fixed and movable contacts). Thus, duplication of the contact points may reduce the probability of error occurrence by half.

Fig. 16. Twin contact

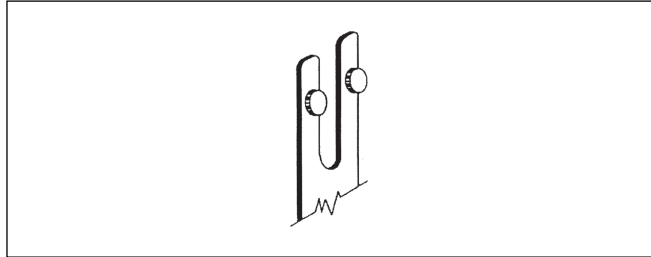

Contact materials

In the issues related with switching, contact materials and special alloys play an important role, and each application requires the appropriate assessment of the electric load, ambient conditions and other information in order to make the proper choice.

Surface finishing

Precious contact materials are widely used due to their high conductivity. However, it is silver and its alloys that are exposed to the effects of the surface corrosion caused by sulfur contaminations in the atmosphere (SO_2 - sulfur dioxide). Layers of sulfur deposit on the contact surfaces, which is highly harmful

to the contact resistance. The aforementioned materials may be plated with gold or another noble metal (metals that are more resistant to corrosion and/or oxidation, i.e. platinum, palladium, etc.).

Cleaning

Cleanliness is very important for the process of relay assembly due to the necessity to keep the internal parts of relays free of dust and other particles which may affect the area between the contacts and disturb the proper course of switching operations.

That is why contacts, working parts and (in some applications) the whole relay without a dust cover are cleaned immediately prior to their enclosing.

Plastic contaminants

Due to temperature, internal parts of the relay made of plastic may produce gases and vapors. If they are not removed from the relay, they may deposit on the contact surface, which will increase the contact resistance. This is often the case in tight relays where it may appear extremely dangerous if the plastic has not been previously treated in a special manner.

The treatment consists in high-temperature degassing process in which, at low atmospheric pressure, plastics emit gases and vapors. The process ends with stabilization of the ambient pressure which allows avoiding reactions inside the relay that might occur in the presence of humidity and oxygen.

Contact resistance and influencing factors

The main function of electric contacts is to close an electric circuit to provide flow of current (I) at voltage (U). This "simple" operation requires certain special characteristics of contacts, which depend on materials, shapes, mechanical parameters, etc. When current (I) flows through an electric circuit, the circuit resistance (R) reacts against the current flow according to the following rule: $U = R \times I$

The value of R consists of two different resistances: **circuit resistance R_c and contact resistance R_r** .

Thus:

$$R = R_c + R_r \text{ and } U = I \times (R_c + R_r)$$

The dissipated power P_w in the entire circuit equals:

$$P_w = P_c + P_r = (R_c + R_r) \times I^2$$

The value of the circuit resistance R_c usually spreads evenly along the length of the circuit (cables, wires, printed circuits, etc.), and P_c dissipates in the same manner (low increase of temperature); on the other hand, however, R_r is entirely concentrated inside the relay (problems related with the temperature rise). This proves the extremely important role of maintaining the relay contact resistance on as low a level as possible. This is important in applications of both high and low power. In the first instance, there is the problem of temperature rise inside the relay whereas in the second case high contact resistance may disturb the proper operation of the device.

Question:

Find the values of power (W) dissipation in the relay contact circuit under the following circumstances:

- electric load: $I = 5 \text{ A}$, $U = 250 \text{ V AC}$,
- relay contact resistance (m Ω):

- a) 10 m Ω
- b) 50 m Ω
- c) 300 m Ω

Solution:

- a) $R_c \times I^2 = 10 \text{ m}\Omega \times (5 \text{ A})^2 = 0,25 \text{ W}$
- b) $R_c \times I^2 = 50 \text{ m}\Omega \times (5 \text{ A})^2 = 1,25 \text{ W}$
- c) $R_c \times I^2 = 300 \text{ m}\Omega \times (5 \text{ A})^2 = 7,50 \text{ W}$

Based on the above, it may be stated that the power dissipation inside the relay reaches undesirable levels at high contact resistance.

Fig. 17. Basic circuit

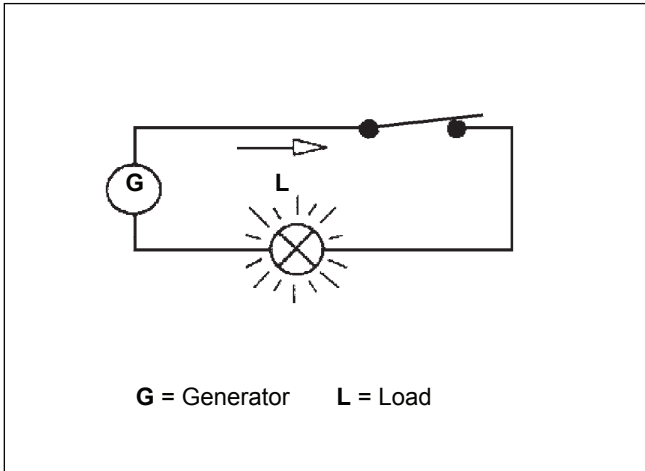

Question:

Find the value of the voltage drop caused by the relay contact resistance in the next circuit under the following circumstances:

- electric load: $I = 1 \text{ mA}$, $U = 5 \text{ mV}$,
- relay contact resistance (m Ω):

- d) 10 m Ω
- e) 100 m Ω
- f) 400 m Ω

Solution:

The voltage drop on the contact equals:

- d) $R_c \times I = 0,01 \times 0,001 = 0,01 \text{ mV}$
- e) $R_c \times I = 0,10 \times 0,001 = 0,10 \text{ mV}$
- f) $R_c \times I = 0,40 \times 0,001 = 0,40 \text{ mV}$

High values of resistance cause a significant percentage of voltage drop which may be dangerous in some devices. This is important because high contact resistance usually means instability of the contact resistance. In applications of low-level signals (measurements, etc.) the capability of reaction to the contact resistance is a fundamental requirement. The following factors affect the contact resistance:

- contact pressure
 - materials
 - surface finishing
 - cleaning
 - internal contaminations of the plastic relay parts.
- Each individual influence must be taken into account.

Alloys and contact materials

The choice of the contact material depends on the application. The following are the most commonly used materials:

Silver Ag

Pure silver (99% Ag) is of the highest electrical and thermal conductivity as compared to any other known metal, and it proves good resistance to oxidation but it is affected by the presence of sulfur in the atmosphere. The sulfur forms silver sulfide which increases the contact resistance. In order to avoid the problem, the contact surface is plated with gold (5 μm) as the latter remains free of silver sulfide (no chemical reaction). This is a good version of the contact widely used for switching low-level loads from μV to 24 V DC and AC, and from μA to 0,2 A, and in any case with no electric arc as it might damage the layer of gold and expose silver to the harmful presence of sulfur.

Silver - cadmium oxide AgCdO

This compound (90% Ag - 10% CdO) has a wide range of applications in power loads owing to its good resistance to welding and the effect of electric arc suppression. The compound may be used from 12 to 380 V AC and from 100 mA to 30 A. It is used particularly for resistive and inductive applications such as motor loads, heating resistors, lamp loads, solenoids, etc. The material is a standard one to meet most of the requirements of the customers. The problems related to sulfur do affect it but the presence of electric arc and relatively high voltage and intensity of current make the problem imperceptible (the electric arc and voltage pierce the sulfide layers).

Silver - nickel AgNi

The alloy (90% Ag - 10% Ni) is the most suitable one for switching DC loads and avoiding material transfer that appears at DC and at medium voltage and intensity of current (1-10 A; 6-60 V DC). This is a physical phenomenon of moving the material from one contact to the other (from cathode (-) to anode (+)). This results in quick wear of contacts and dangerous reduction of the contact clearance.

Tungsten

This is the hardest material, highly resistant to sticking. It has, however, a relatively high contact resistance. Because of these characteristics it is usually used in electric circuits where short current peaks appear, and where the material prevents the contacts from welding to each other: leading loads, motor loads, lamp loads (especially fluorescent lamps), etc. The range of applications starts from 60 V and 1 A.

Silver + tin oxide (tin dioxide) - AgSnO₂

The AgSnO₂ material is of similar properties to those of AgCdO. However, the former has a higher thermal stability and better resistance to transfer of material from one contact to the other, which provides longer life in DC applications. The AgSnO₂ contacts wear evenly and they are recommended for applications at the loads that create inrush current and at inductive loads.

The contact ratings depend to a great extent on the level of the oxide in the compound, the manufacture method and the presence of admixtures which are used by contact materials manufacturers mainly to reduce the contact resistance and to enhance the resistance to material transfer.

The AgSnO₂ material offered by Relpol S.A. in miniature relays contains a low admixture of indium oxide (In₂O₃) which is a universal material. Apart from good results achieved at lamp loads, the material performs perfectly at resistive loads and switching currents up to 16 A.

Gilding - Au

Contact gilding with 0,2-0,5 μm gold layer is usually applied in order to protect the basic material from oxidation during product storage. The protective gilding is not resistant to mechanical wear and it is quickly destroyed in course of the relay switching. Contact gilding with 3-5 μm layer of gold is used as protection from corrosion and to enhance signal circuits switching. Thick gilding provides the lack of microscopic pores, perfect resistance to corrosion and to formation of non-conductive layers. However, gold is very soft, easily becomes mechanically worn, and its low melting point may limit the electric life of the contacts which switch high currents.

Fig. 18. Transfer of contact material

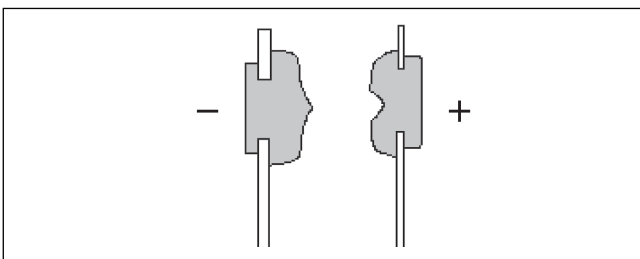

Electric life of relays

The electric life or switching capacity is expressed as the minimum number of cycles which the relay may perform at a given load and under certain circumstances. The "cycle" means a full switching operation from OFF state to ON state and to OFF state again. The electric life ends when the contacts are no longer capable of switching electric load within the range of

the contact resistance (or contact voltage drops) which stops the switching operations after it has reached a higher value (the limits depend on the application). The specifications of relays indicate the electric life as the number of cycles at rated current and voltage, and at constant frequency and ambient temperature.

For example, the electric life of the RM85 relay is:
Number of cycles: 7×10^4 at 16 A and 250 V AC - 50 Hz, resistive load, 600 cycles/hour - ambient temperature 85 °C.
In practice, customers require electric life also at lower values of current intensity. Thus, on the basis of tests, the curve of electric life is defined and the curve shows the dependence of electric life (number of cycles) on switching capacity (Fig. 19).

Inductive loads cause high contact wear which reduces the relay life. The reduction has been defined on the basis of tests, and it is expressed as the correction factor for resistive electric life (depending on the load power factor) which should be used to define the projected life.

Question:

What is electric life of the RM85 type relay for the following electric load: 8 A / $\cos\phi = 0,4$ / 250 V AC; 600 cycles/hour. The chart in Figure 19 shows that the projected life is approximately 150 000 cycles at resistive load ($\cosine = 1$).
The chart presented in Fig. 20 proves that at the cosine power factor which equals 0,4 the correction factor is 0,7. Thus, the projected electric life under the aforementioned conditions is $150\ 000 \times 0,7 = 105\ 000$ cycles.

Fig. 19. Chart of electric life of a relay

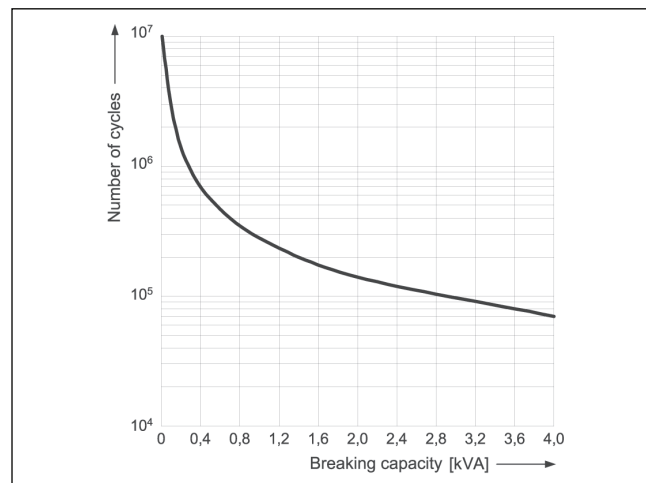
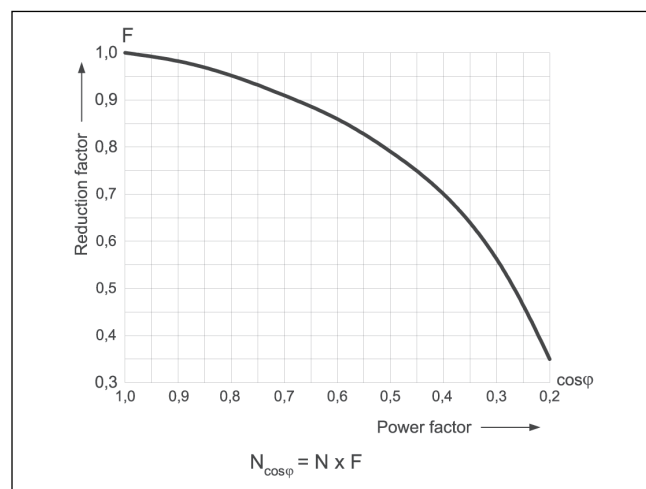

Fig. 20. Ratio of correction coefficient to power coefficient



Reliability

Charts of electric life of a relay in the function of load power are useful in estimating the reliability parameters. The value found in such charts may be used for defining the statistical parameter of B10 life, i.e. the number of cycles following which 10% of the relays population will fail. Electromagnetic relays are unreparable elements and, thus, any damage to them

in a device means the necessity of replacement. Given the frequency of operations of a relay in a device and the number of cycles defining its life, the mean time to failure (MTTF) may be estimated, which may then be used for calculation of MTBF for the device.

Switching at alternating and direct current

Various problems occur at switching AC and DC loads of high power, and various aspects shall be taken into account in order to understand the nature of the phenomenon. In AC current circuits (of the frequency approx. 50 - 60 Hz), the relay contacts may open in two possible states of the operating voltage due to the course of the voltage and the phenomenon of the electric arc (see Fig. 21).

Switching at point I:
Voltage value is close to zero.
No electric arc occurs.

Switching between points I and II:
There may be two situations in which the voltage grows or drops. In both cases, arc discharge occurs but it is suppressed due to the transfer of the voltage via the zero value. The electric arc discharge depends on the voltage value, contact clearance, current intensity, shape of contacts and on materials. Due to

Fig. 21. Switching states (I, II) at the frequency of 50 Hz of alternating current

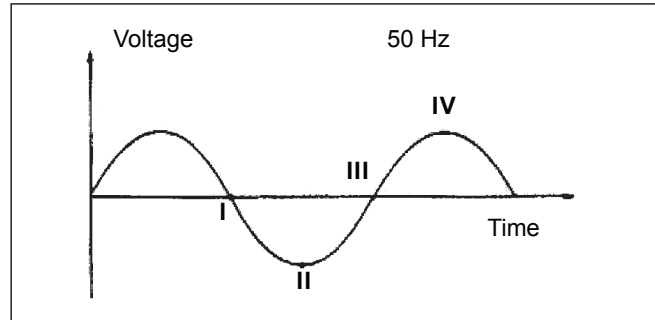

these reasons, in miniature relays there are physical limits related to the above parameters, which reduce the maximum AC switching voltage to approximately 380 V. The inductive loads of AC are worse as compared to the resistive loads due to contacts wear since the load inductance grows and, thus, a constant arc appears together with its harmful effects.

Arc breaking

In DC devices, the arc breaking is a crucial problem because the voltage does not transfer via the zero value as it does at alternating current. Thus, when the electric arc appears, only the contact clearance and the properties of the contact materials contribute to the arc suppression. Relays usually have a physical limit that depends on the above parameters which make the relays incapable of switching the load at current intensity and voltage higher than the specified values. The values are expressed in the form of a curve which defines the maximum switching energy ($U \times I$) at the constant time value L/R of resistive and inductive loads while L (inductance) is expressed in henries and R (resistance) in ohms. L/R is principally expressed as a value that equals 40 ms (milliseconds) for inductive loads, i.e. a mean value for devices.

Example (Fig. 22):
The maximum admissible switching intensity of direct current for the R3N relay at 230 V DC at resistive and impedance loads are 210 mA and 120 mA respectively. The values assure the arc suppression. Suppressing circuits are also useful for alternating current devices.

Fig. 22. Maximum switching capacity at direct current

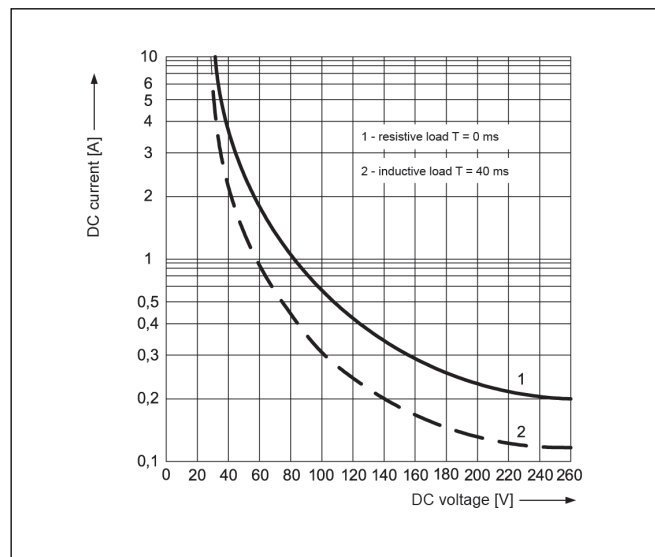

Suppressing circuits

In order to protect contacts against their damage by electric arc, protection circuits are used which are fitted in parallel to contacts of the relay or to the load. Appropriate suppressing elements may also be connected both to the contacts and the load.

The most common method of arc suppression in DC circuits is using a **diode** in parallel to the load. This is an efficient and cost-saving solution applicable at various values of the load. The inverse voltage of the diode should be at least 10 times higher than the rated voltage of the circuit, and the conduction current should be equal to or higher than the load current. It

must be emphasized that diodes prolong the time of switching off the relay considerably, which delays opening of the contacts and this is conducive to their burnout.

In order to decrease the effect of the arc suppressing circuit, on switching off the load, **two Zener diodes** may be used instead of the diode parallel to the load. In such a circuit, the inverse voltage is limited by Zener diodes to the regulated voltage. The breakdown voltage of the Zener diode must be higher than the supply voltage of the circuit. The disadvantage of this solution is its lower effectiveness and higher cost.

Fig. 23. Protection circuits

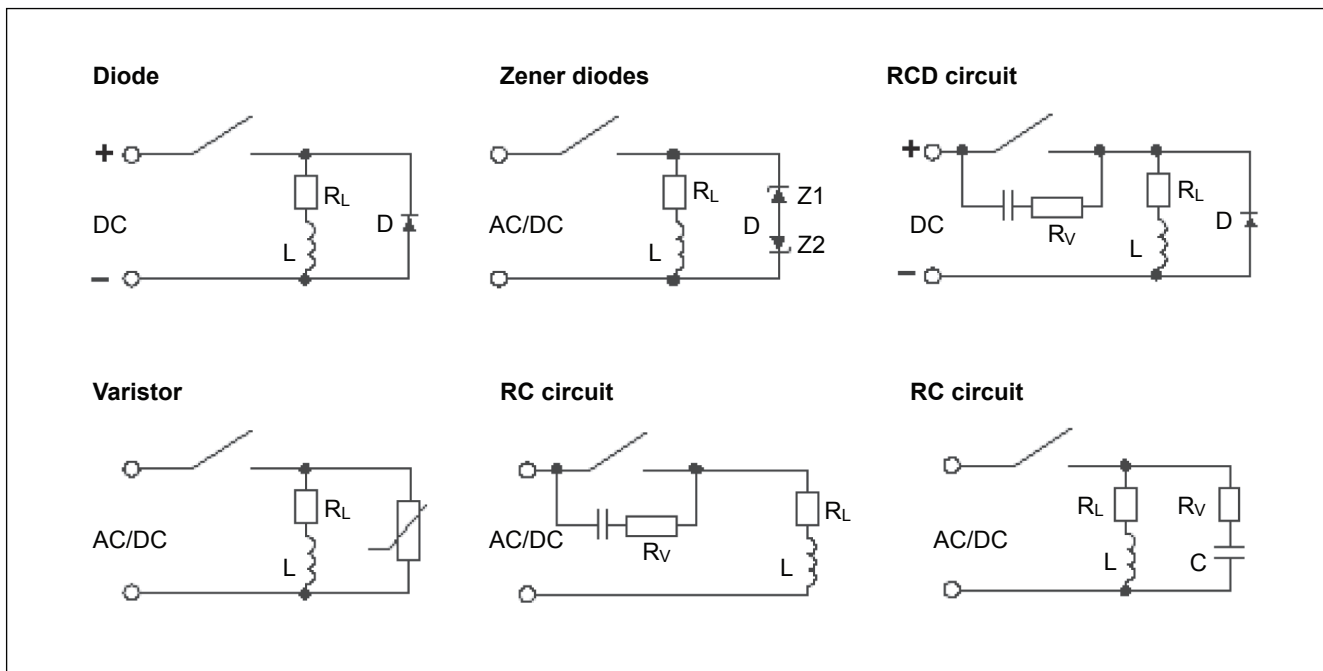

A **varistor** is another protection element of current-voltage characteristics similar to Zener diode. For low voltages it shows high resistance and, then, it is practically disconnected from the circuit whereas when the voltage exceeds certain voltage, characteristic for the given varistor, its resistance decreases quickly and, then, it shunts the inductive load with its internal resistance.

Unlike diode and varistor circuits, **RC circuits** may be connected in parallel both to the load and to the contacts of the relay. When the contact opens, the capacitor connected in parallel starts charging itself and its voltage grows at the time constant of R and C values.

This helps to maintain low voltage on the relay contacts and, thus, diminish the effect of the electric arc. When the contact closes, the capacitor connected in parallel to the capacitor consists limitation of current. Thus, the RC circuit optimizes all the intermittent processes in the course of opening and closing of the contacts. At AC voltages the load impedance must be lower than the RC circuit impedance.

In order to enhance the effectiveness of arc suppression in direct current circuits of high inductiveness of the load, **RCD circuits** may be used, where the RC element is connected in parallel to the relay contact and the diode - in parallel to the load.

Fig. 24. Nomogram for defining optimal values of R and C

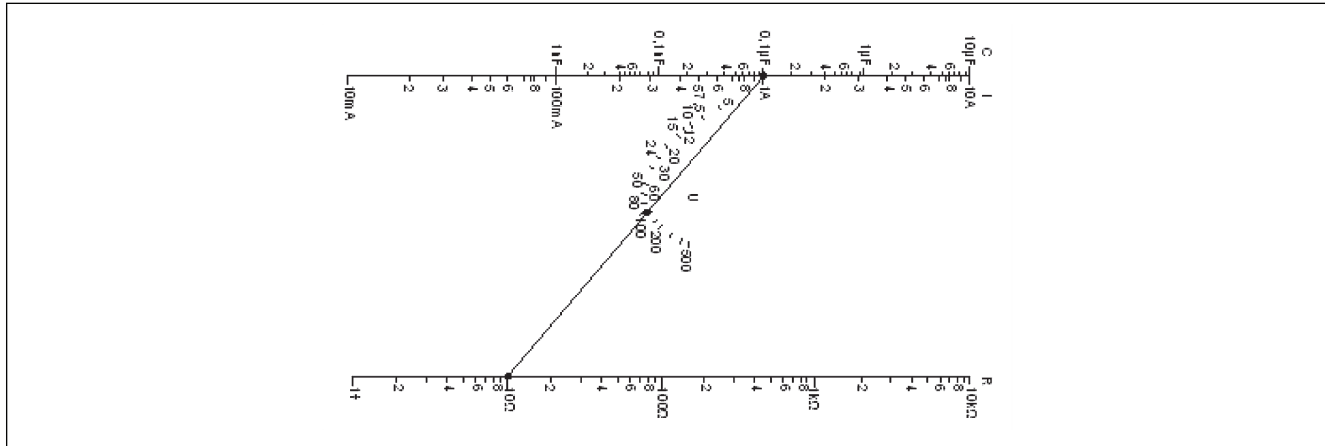

Special loads

Bulb load

Closing of the contact with bulb loads (a lamp with tungsten fiber) causes problems due to high current peaks related with the low resistance of the fiber when it is cold. For example, a 60 W - 220 V AC bulb has the "cold" resistance of approximately 60 Ω which corresponds with a current intensity of 3,66 A (for a few milliseconds). On the other hand, the current intensity of a hot bulb is 0,273 A (the ratio is then 1:15). This illustrates the high load that occurs on the contacts during the bulb switching (a hazard of contact welding or sticking).

The following must be taken into account for bulb load switching:

- maximum load of the bulb
- contact material

For example, for the RM96 relay with AgCdO contacts the maximum admissible bulb load is some 1,000 W which corresponds with the current intensity of 4,5 A and the alternating current voltage of 220 V. In other relays of higher loads the contacts are made of AgSnO₂.

Motor loads

The motor loads are inductive loads which operate in a particular manner while switching on. A current peak occurs as a result of the motor inertia which is related to the mechanical load used in the motor, and which in the starting phase is 5-10 times higher than the current in the steady state. Furthermore, when the motor is being switched off, harmful action related with impedance loads occurs. Thus, the correct choice of contact

material is related with the aforementioned load characteristics, especially when the capacitor is connected to the motor. In such particular cases, the contacts are made of tungsten and AgSnO₂. The motor load is usually expressed in HP (horsepower) where 1 HP equals approximately 745 W.

Example: R15 relay - the rated motor power of the contact is 1/2 HP.

Capacitance loads

This is the worst contact load as for switching on due to a sudden increase of the current intensity peak which occurs when the capacitor is discharged (a phenomenon similar to a short circuit). The current intensity at the peak to be switched on may reach the values of hundreds of Amperes in a very short time (microseconds).

The problem of contact welding may be avoided in two ways:

- via using the AgSnO₂ contacts,
- via reduction of the current intensity peak by introduction of a resistor to limit the current.

The same problem occurs at contacts closing with a charged capacitor, i.e. a rapid discharge occurs.

Switching time and contact bounce

On the relay coil supply during opening and/or closing, the operation lasts in time depending on the electric and mechanical inertia of the parts. The delay between the coil supply

impulse and the preset closing and/or opening of the contacts is the sum of the effect of the electromagnetic system and the switching section.

Electromagnetic system

The current flows through the coil with the delay caused by the coil inductance which resists to the current stream. Further-

more, the movable parts such as the armature and the pusher react to the movement due to the action of the magnetic stream.

Switching section

The elastic forces stored in the contacts and springs, and their elastic strain, react to the movement of the relay parts. The phenomenon is also affected by the inertia of the contacts mass. The delay times of the miniature relays usually reach the value of a few milliseconds (5-15 ms) during the switching

phase. During the release phase the operating time is shorter due to the absence of the magnetic circuit delay. It is really so that on removing the supply voltage from the terminal, the current that flows through the coil wire stops suddenly and the relay is released with the elastic energy stored in the contacts.

Fig. 25. Switching time

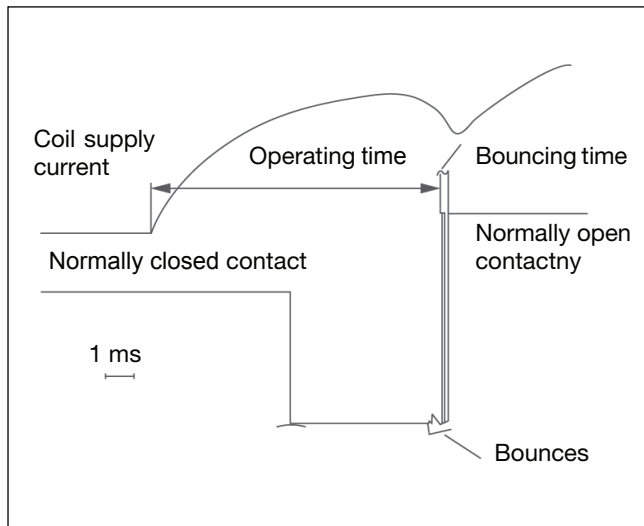

The **operating time** of an inactive relay is the time interval from the moment of the supply of the voltage to the relay coil to the time of the first closing (or opening) of the contact. If the relay has more than one contact, the time of closing (or opening) of the last of the contacts is taken into account. The operating time includes the time of opening the normally closed contact and the time of closing the normally open contact.

Fig. 26. Release time

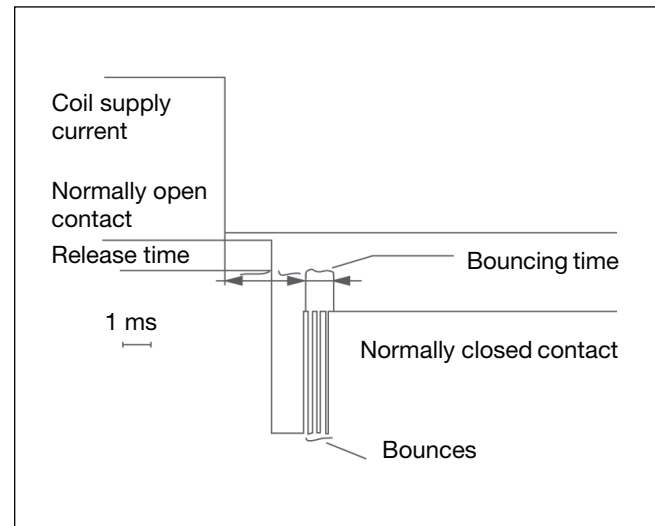

The **release time** of the active relay is the time interval from the absence of the supply voltage to the first opening (or closing) of the contact. If the relay has more than one contact, the time of opening (or closing) of the last of the contacts is taken into account. The release time includes the time of opening of the normally open contact and the time of closing the normally closed contact.

Bouncing

In the phases of switching and release, when the contacts close, they never perform the operation at the same time but the clash between two contacts makes the contacts bounce.

The "contactbouncing" cause constant closing and opening of the contacts. This particularly affects the contact ratings such as electric life and signal switching.

Sinusoidal vibrations

The electromechanical relay is strongly affected by dynamic phenomena which may change its projected characteristics constantly or temporarily. The devices in which vibrations occur must be thoroughly tested so that we might find out the quality and essence of the stress. Machine tools, automotive devices, assembly machines, and principally every instrument in which the electronics of the drive is affected by the presence of movable parts (motors, vibrators, valves, etc.), may be exposed to the consequences of the problem. Relpol S.A. usually tests the relays via exposing them to sinusoidal vibrations at the constant acceleration (G) within a particular range of frequency. Moreover, the relays are tested along the main axes (x, y, z) and in two basic directions for each axis. As a rule, the relays are tested with the printed circuit board mounted (sockets, materials, etc.).

The tests are made in two stages, i.e. resonant test and fatigue test. The relays are tested at the states where the coil voltage

is on or off. The contact continuity is monitored with an oscilloscope at a low-level load on the contacts. The test allows defining of the frequency range [Hz] and maximum value of the acceleration, at which the relay may operate with no loss of contact continuity (interval of 10 μ s) or without any durable damage. The standard values (which meet the requirements of a wide line of devices) for miniature relays reach 10 G at the frequency range from 25 to 100 Hz. The values refer to the worst case which usually occurs in the most critical test conditions (the relay with no supply in a given axis of vibrations). For tests at a low frequency range (a few hertz), instead of the constant acceleration, a constant movement is simulated which corresponds with a given value of acceleration (e.g. from 10 to 25 Hz for the amplitude of 2,5 mm). The tested frequency at which the constant movement changes into the constant acceleration is called the "transition frequency", e.g. at 55 Hz 10 G it corresponds with 1,5 mm.

Current surges

The maximum value for miniature relays is 10 G for maximum peak acceleration and 11 ms of the impulse duration. As for the sinusoidal vibrations, the sample shall be subject to an ohm test for surge both at the ON and OFF states within the arrangement

of the three main axes (x, y, z), in two basic directions for each axis. Three surges shall be applied to each state. The tested relay shall not open the contacts (10 μ s interval), and it must operate perfectly at the end of the test.

Hermetic relays - soldering and cleaning

The necessity to use tightly closed and hermetic parts in devices arises from two different reasons, i.e. protection of the internal parts (contacts, mechanisms, wires) from penetration

of the stream in the process of soldering and cleaning, and protection of the internal parts from atmospheric contamination.

Relay handling during PCB assembly, soldering, cleaning and PCB coating

Handle the relays carefully. Any hitting the relay or dropping of the relay, even from a small height onto a hard surface generate very strong mechanical shock, can cause permanent damage, change of mechanical parameters and improper operation. If the relay has fallen, we recommend you reject it and apply a new one.

Mounting the relay: bending the relay pins is forbidden because it can damage the relay.

Manual soldering: soldering iron power max. 60 W, max. iron tip temperature 360 °C, soldering time max. 3 s. Exceeding the given process parameters may damage the relay.

Flux application: it is recommended to use modern fluxes (no-clean type) to eliminate the need to wash the PCB after assembly. Be careful careful when applying flux. Make sure that the flux is applied in the minimum necessary amount, only from the bottom of the PCB on the pin side and does not flow onto the top of PCB. Failure to follow this precaution may result in damage the relay.

Wave soldering: applies to relays with protection class RTII and RTIII. The level of solder wave should be set so that it does not overflow onto the surface of the PCB. The solder temperature must not exceed 270 °C and the soldering time must not exceed 5 seconds. During pre-heating, the temperature on the component side should not exceed 100 °C. After automatic soldering, the PCB with the relays should be cooled down before the washing operation. The cooling speed should not exceed 5 °C/s to not damage the relay sealing due to thermal shock.

The PCB cleaning process: is only allowed for relays with RTIII protection class with a closed vent hole. Avoid cleaning in a cold liquid immediately after the soldering process because thermal shock causes the relay to become unsealed as a result of the pressure difference and the cleaning liquid and/or flux can get into the relay inside. The penetration of the flux into the relay inside may result in sticking of the armature or contamination of the contacts, which leads to incorrect work of the product. Additional care should also be taken to avoid penetration of the liquid inside the relay - too high washing pressure can damage the sealing of the relay. Recommended cleaning solvent temperature max. +40 °C.

It is forbidden to wash in ultrasonic washers, it may cause damage to the coil or welding contacts as a result of ultrasound.

It is recommended to use alcohol-based or aqueous cleaning solvents for PCB cleaning. When using other cleaning solvents, the user should ensure that they do not have a negative impact on the materials from which the relay is built. Unsuitable cleaning solvents include: acetone, ethyl acetate, solutions based on solvents or chlorine.

Application of conformal coatings: applies only to relays with RTIII protection level. Conformal coatings for unsealed relays (including relays with RTII protection level) should not be used. The materials for conformal coatings should be carefully selected - some materials are chemically active and have a destructive impact on the relays, eg. they can penetrate inside the relay or damage the relay seal, cause the relay to malfunction. Avoid silicone-based coatings.

Environmental contamination

The environment of the relay may adversely affect its operation. Humidity, industrial air, dust and particles that penetrate the inside of the relay may affect the contacts, internal parts and isolation. The environmental conditions in which the relay and the device will be used shall be analyzed in order to avoid such problems as resistance growth and corrosion of the metallic parts.

If the ambient conditions are not arduous and/or the electric load of the contacts is not critical (cleaning presence of the arc), it is better to open the relay following the soldering and cleaning processes to allow the useful exchange of the air with the external atmosphere.

What is important for the thermal exchange (high switching power) is the gas emission caused by the electric arc and the residual contaminations with plastics. As explained before, the process of sealing the relay includes degassing of plastics, filling the relay with inert gas (nitrogen), and the process of label closing or other methods.

Fig. 27. Opening of the relay

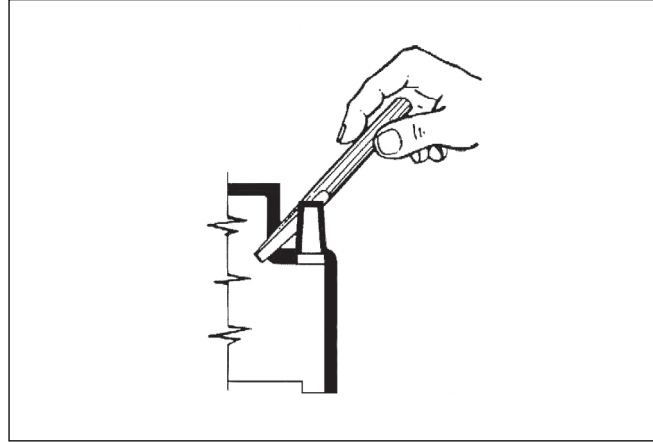

Lead-free soldering

Eliminating of the lead used in the solders required both changing of the material and the production process which had to be adapted to different properties of the lead-free materials. The differences between the physical properties of lead alloys and their lead-free equivalents available on the market are significant and, thus, the applicable features of soldering alloys shall be thoroughly considered, and the flux must be precisely selected in order to provide optimal conditions for the process. Generally, lead-free alloys have slightly higher melting point, higher surface tension and lower moistening than SnPb. This may cause production problem, i.e. damages to components due to thermal impacts, deforming of the PCB's, flux splashes, extending of the operation time to good joining, deforming of plastics, etc.

Sn97Cu3 and Sn99Cu1 are good materials for soldering internal elements and for covering the terminals. They are modern alloys widely applied in electronics owing to their good physical properties. They are also a good and popular alternative for Sn60Pb40 and Sn63Pb37.

In order to provide good tin-plating and soldering of the terminals, it is important to select appropriate flux. Higher melting point of lead-free alloys results in higher oxidation and lower moistening and, thus, appropriate flux must be selected and its quantity shall be adapted to the temperature profile of the process. Too much heat delivered may cause evaporation of flux before it moistens the solder, and use of stronger, aggressive fluxes in higher quantities may require introduction of the operation of washing away the residues of the soldering process.

Types of relay terminals

Surface mounted terminals (SMT)	
THT mounted terminals	
Terminals to solder wires and for sockets	
Terminals for flat slide-in (faston) connections	

In miniature relays of high power to be mounted on printed boards universal terminals are made so to provide fitting the relays also in sockets mounted on **35 mm rail mount**. Then, relay terminals are connected to wires with screw terminals of the socket. This allows mounting miniature relays on a mounting board and enhances technical service of the device. Sockets are fitted with retractor / retractor clips which facilitate dismounting of the relay and, when it is mounted in the socket, the lever serves as a reliable latch which secures the relay on the mounting board.

Electrical connections to voltage and current sources are made with appropriate joints and wires of cross-sections specified in the table aside.

While mounting relays **on printed boards**, the openings on the board must match the raster of the relay terminals and have appropriate diameter, which shall enable its easy connection. Otherwise, terminals may be bent, contacts deformed or the cover tightness may be disturbed. Printed paths from the relay contacts should be as wide as possible, which results in lower losses in the course of current flow and good removal of heat from the contacts. For the purpose of providing good insulation strength, it is necessary to arrange the circuits appropriately on the board and to apply protection mask.

Fig. 28. In course of mounting of the relay in the socket, the clip functions also as a relay protective latch.

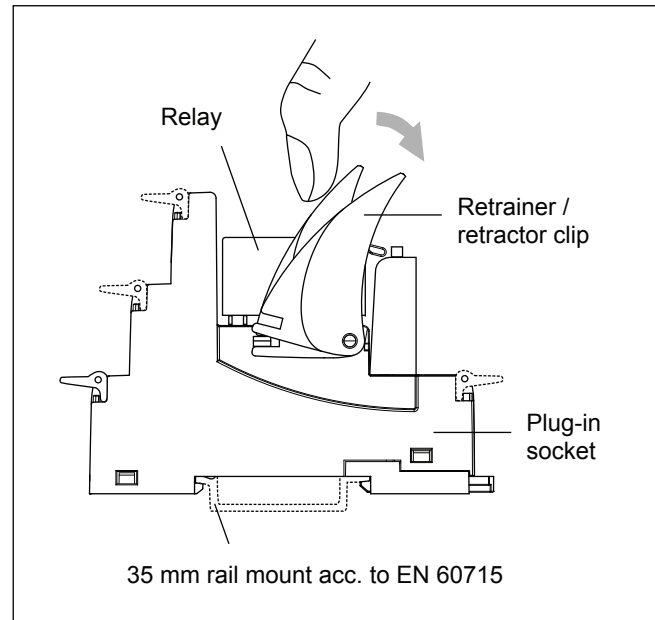

Current flowing via terminal [A]		Wire and stranded conductors cross-section [mm ²]
above	including up to	
–	3	0,5
3	6	0,75
6	10	1
10	16	1,5
16	25	2,5
25	32	4
32	40	6
40	63	10

Fig. 29. Typical rasters of terminals of miniature relays

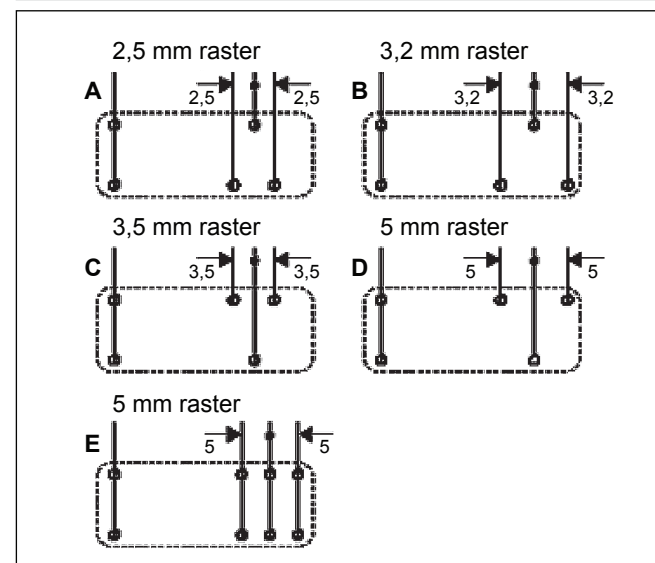

The table shows various **limiting currents** of printed circuits of different thickness of the copper layer and with various conducting paths.

Load current [A]	Width of the copper printed path [mm]			
	Copper thickness 70 µm		Copper thickness 35 µm	
	Single-side path	Double-side path	Single-side path	Double-side path
16	8	5	inadmissible	inadmissible
14	6,5	4	inadmissible	inadmissible
12	5	3	7,5	5
10	3,5	2	6	4
8	2,5	1	4	2,5
6	1,5	is not applied	2,5	1,5
4	1	is not applied	1,5	1
2	0,7	is not applied	1	is not applied

International standards

Relays manufactured by Relpol S.A. are designed and tested in compliance with the requirements of the following international standards:

EN 61810-1 Electromechanical non-specified time all-or-nothing relays. Part 1: General requirements.

EN 61810-7 Electromechanical elementary relays. Part 7: Test and measurement procedures.

EN 60664-1 Insulation coordination for equipment within low-voltage systems. Part 1: Principles, requirements and tests.

EN 61812-1 Adjustable time relays for industrial purposes - Requirements and tests.

EN 61131-2 Programmable controllers. Part 2: Requirements and equipment tests.

Plug-in sockets manufactured by Relpol S.A. are designed and tested in compliance with the requirements of the following international standard:

EN 61984 Connectors - Safety requirements and tests.

Insulation

The classification of insulation groups to define the properties of insulation of the device in compliance with the insulation coordination was previously done according to the VDE 0110 Standard.

Electric devices were classified in insulation categories A, B, C or D due to their application and possible reduction of the insulation properties caused by the impact of the environment, i.e. dust, humidity, aggressive gases, insulation clearance and creepance.

The insulation category was indicated together with the reference voltage which was the basis for defining of the requirements related to the insulation distances for rated voltage up to the reference voltage value.

At present, while dimensioning the insulation distances in accordance with the EN 60664-1 Standard, the overvoltage category and the ambient pollution degree must be defined. The latter indicates the expected pollution of the microenvironment. The transient overvoltage values are the basis for defining the rated surge voltage which determines the minimum contact clearance related with the insulation coordination.

The following **overvoltage categories** are defined:

- IV** - devices at the front of the installation,
- III** - devices in fixed installation in cases where reliability and availability of the device is subject to special requirements,
- II** - receiving devices supplied from the fixed installation,
- I** - devices connected to circuits where measures have been taken (either in fixed installation or in the equipment) to limit transient overvoltage to the appropriately low level.

Four **pollution degrees** have been defined to estimate the contact creepance and clearance:

- 1 - no pollution or only dry and non-conducting pollution; the pollution has no effect.
- 2 - only non-conducting pollution occurs; the vapor condensation, however, may be expected to cause temporary conductivity of the pollution from time to time.

- 3 - conductive pollution or dry and non-conductive pollution occurs which may become conductive due to condensation.
- 4 - the pollution proves constant conductivity caused by the conductive dust, rain or snow.

The **rated surge voltage** is defined on the basis of the overvoltage category and the rated voltage of the device.

The rated voltage of the supply system according to PN-IEC 60038		Phase voltage defined on the basis of AC or DC nominal voltages up to the value of	Rated surge voltage			
			Overvoltage category			
Three-phase	Single-phase		I	II	III	IV
	120-240	150	800	1500	2500	4000
230/400		300	1500	2500	4000	6000

The **insulation creepance** are dimensioned on the basis of the following factors:

- root-mean-square value of rated voltage,
- pollution degree,
- group of insulation materials.

Insulation materials are divided into four groups with reference to the value of the indicator of resistance to creeping current:

- Group I** $600 \leq CTI$
- Group II** $400 \leq CTI \leq 600$
- Group IIIa** $175 \leq CTI \leq 400$
- Group IIIb** $100 \leq CTI \leq 175$

Insulation materials testing

1. Glow wire test

The test simulates exposure to heat originating from such heat sources as glowing parts or overloaded subassemblies in order to assess fire hazard.

The consistency with the requirements for resistance to heat and fire is checked in glow wire test at the temperature of 650 °C.

Some applications of the relay extort more strict requirements. The EN 60335-1 Standard: "Household and similar electrical appliances", provides that the insulation parts supporting elements which conduct current higher than 0,2 A must meet the following requirements as for resistance to fire:

- a) GWFI (Glow Wire Flammability Index) with a value 850 °C according to the EN 60695-2-12 Standard.
- b) GWIT (Glow Wire Ignition Temperature) with a value 775 °C according to the EN 60695-2-13 Standard.

2. Ball pressure test

The purpose of the test is to assess the resistance of the material to mechanical pressure at higher temperature with no significant deformations.

The test is performed in a heating chamber at higher temperature, where a steel ball of 5 mm diameter is pressed to the surface of the sample with the force of 20 N. The diameter of the indentation shall not exceed 2 mm. The test is made under EN 60695-10-2 Standard.

3. Resistance to proof tracking

The test shows relative resistance of solid insulation materials to proof tracking for voltages up to 600 V when the surface of the insulation, at electrical tension, is exposed to contaminated water.

Proof tracking is probable between parts of different potential and between live parts and earthed metal parts.

Compliance with the requirements is checked under the EN 60112 Standard for PTI index.

In case the type of the relay application requires more strict requirements, PTI 250V, PTI 400V or PTI 600V proof tracking resistance indices shall be assumed.

Electromagnetic compatibility

Electromagnetic compatibility is the ability of an electric or electronic appliance to operate correctly in a given electromagnetic environment and not to emit disturbances not tolerated by other appliances which operate in the same environment. The relay is insensitive to high frequency disturbances but presence of high power electromagnetic fields in the proximity of the relay coil may affect making and releasing voltages of the relay. On installation of a relay in the proximity of transformers, electromagnets and electric motors, it is recommended to check making and releasing of the relay.

An electromagnetic relay may initiate disturbances, particularly when operating with inductive load of contacts. An electric arc occurring while switching, and overvoltage cause emission of disturbances which may affect the operation of a sensitive electronic appliance in the proximity of the relay. In such cases, circuits of protection of contacts shall be applied, which will allow decreasing the level of disturbances to a safe level. Relays, as components, are not covered with the **EMC** Directive. However, each electric appliance which includes relays is covered with the Directive and subject to its requirements.

EMC test	Standard
Resistance to electrostatic discharges	EN 61000-4-2
Resistance to electromagnetic field of radio frequency	EN 61000-4-3
Resistance to quick pulse beams	EN 61000-4-4
Resistance to surges	EN 61000-4-5
Resistance to conductive disturbances induced by fields of radio frequency	EN 61000-4-6
Resistance to voltage dips, short breaks and changes	EN 61000-4-11
Measurements of radiated and conducted emissions	EN 55011

The most frequent disturbances in installations are quick, repeatable transient states - beams of electric disturbances called **BURST**. These are transient disturbances occurring in supply, signal and control connections. They origin from transient switching states and occur on switching by the contact of

inductive loads - electromagnets, motors, etc. They have the form of a beam of high voltage and low power pulses, as the pulse increment time is merely 5 ns and its duration is 50 ns. In tests the duration of a pulse beam is defined as 15 ms, and the period - 300 ms.

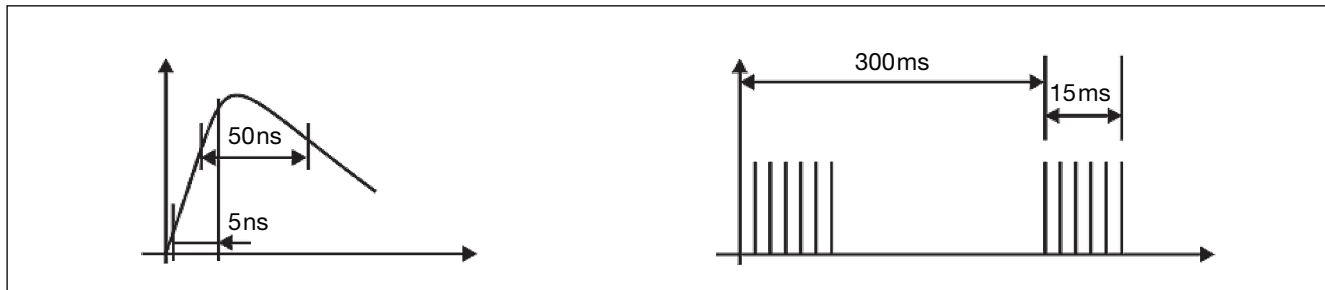

Another type of disturbances occurring frequently, due to atmospheric discharges, in low voltage installations are surges (**SURGE**) in supply lines. Similar disturbances may be also caused by connection processes of high power, e.g. switching of leading loads, etc. Surge pulses are of definitely higher power than burst pulses due to much longer duration - 50 μ s.

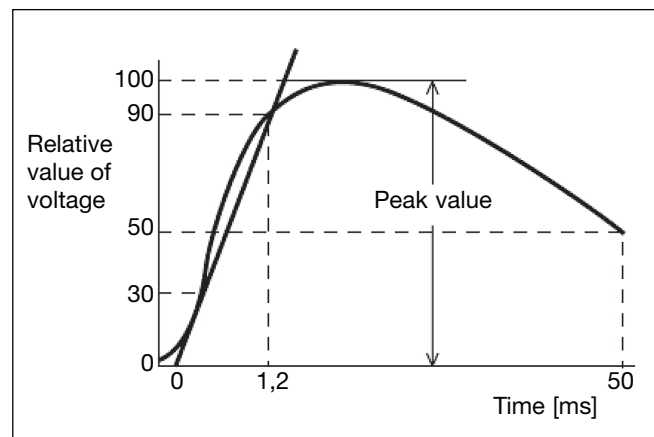

Protection against ambient effect

As for the protection from **ambient effect**, the EN 61810-7 Standard distinguishes the following types of relays:

RT0 - open relay - a relay without protective cover.

RTI - dust protected relay - a relay with cover to protect its mechanism from dust.

RTII - flux proof relay - a relay adapted to automatic soldering process without allowing the migration of solder fluxes beyond the intended areas.

RTIII - washable relay - a relay adapted to automatic soldering process and then subject to washing process for the purpose to remove flux residues without allowing the ingress of flux or washing solvents. Note: the relays shall not be washed in ultrasonic cleaners. RTIII relay are tested to evaluate sealing acc. to EN 60068-2-17, Qc test.

RTIV relay sealed - relay provided with a case which has no venting to the outside atmosphere and having a time constant better than 2×10^4 s in acc. with EN 60068-2-17.

RTV - hermetic relay - a tight relay of enhanced tightness level, in a metal cover, terminals sealed with glass, gas-filled.

Cover protection degrees according to EN 60529 Standard. The first digit refers to the protection from foreign solids penetration. The second digit refers to the protection from water penetration.

Examples of indications:

IP 20 - protection against solids of the diameter of 12,5 mm and larger, with no protection against water penetration.

IP 40 - protection against penetration of solids of 1 mm diameter and larger, with no protection from water penetration.

IP 50 - protection against dust; dust penetration is not excluded entirely but dust shall not penetrate in quantities which might disturb correct operation of the appliance or reduce safety.

IP 64 - dustproof protection, protection against water splashes - water splashed onto the cover from any direction does not cause harmful effects.

IP 67 - dustproof protection, protection against the effects of momentary submersion in water.

Ambient conditions

Storage and use of the relays is not allowed in the conditions which may cause steam condensation and/or icing.

The relays shall be stored and used at temperatures specified in catalog cards of individual products.

Admissible relative humidity for storage and operation within the range of 5...85% (with no condensation and/or icing).

Atmospheric pressure: 86...106 kPa

Climatic resistance:

Cold: 16 h at minimum temperature defined for the product according to the Standard EN 60068-2-1.

Dry heat: 16 h at maximum temperature defined for the product according to the Standard EN 60068-2-2.

Humid heat: 2 cycles 12 h each at temperature of +25...+55 °C and at humidity 90...95%, according to the Standard EN 60068-2-30.

Electric load

Electromagnetic auxiliary relays manufactured by Relpol S.A. are designed for a wide range of applications and for switching several loads of diversified characteristics.

Electric loads are classified according to their nature (resistive, capacitive or inductive loads), type of supply (DC or AC), load value and the current curve course shape (lamp, motor, electromagnetic, etc. loads).

Contact application categories according to EN 61810-7 Standard

Application category	Voltage [V]	Current [A]
0 (CA 0)	< 0,03	< 0,01
1 (CA 1)	0,03 < U < 60	0,01 < I < 0,1
2 (CA 2)	5 < U < 250	0,1 < I < 1
3 (CA 3)	5 < U < 600	0,1 < I < 100

Application categories according to EN 60947-4-1 and EN 60947-5-1 Standards

Application category	Typical application
AC-1	Resistive or slightly inductive loads, resistance furnaces
AC-2	Slip-ring motors: start-up, switching off
AC-3	Squirrel-cage motors: start-up, switching off motors during running time
AC-4	Squirrel-cage motors: start-up, reversing (countercurrent braking), pulsing
AC-5a	Discharge lamps
AC-5b	Electric bulbs
AC-6a	Transformers
AC-6b	Capacitor banks

Application categories according to EN 60947-4-1 and EN 60947-5-1 Standards

Application category	Typical application
AC-7a	Slightly inductive loads in household appliances and similar applications
AC-7b	Motors in household appliances
AC-8a	Hermetic refrigerant compressor motors with manual overload resetting
AC-8b	Hermetic refrigerant compressor motor control with automatic overload resetting
AC-12	Control of resistive loads and solid state loads with opto-isolators
AC-13	Control of solid state loads with transformer isolation
AC-14	Control of small electromagnetic loads (≤ 72 VA)
AC-15	Control of AC electromagnetic loads (> 72 VA)
DC-1	Resistive or slightly inductive loads
DC-3	Shunt-motors: start-up, breaking
DC-5	Series-motors: start-up, countercurrent braking, pulsing. Dynamic switching-off of DC motors
DC-6	Bulbs
DC-12	Control of resistive loads and solid state loads with opto-isolators
DC-13	Control of DC electromagnets
DC-14	Control of DC resistive loads having economy resistors in the circuit

Certifications

Compliance with national and international standards provides for safe use of the product, and proves high quality and durability of the product. In some countries (e.g. USA, Canada, Russia), the product certification to prove its compliance with the requirements of appropriate national standards is obligatory, and the product must undergo the procedure of compliance assessment at certifying agencies in order to be approved for sale. In other countries it is the manufacturer's responsibility to provide the compliance of the design and production with the requirements of appropriate standards (e.g. the countries of the European Union).

Certification agencies carry out the testing procedure in accordance to applicable standards, and then they regularly audit the production process in order to confirm that the requirements are observed in current production of the certified product. The European Union applies European Standards (EN) as set forth by the European Committee for Electrotechnical Standardiza-

tion (CENELEC), and international standards set forth by the International Electrotechnical Commission (IEC).

The products manufactured and offered by Relpol S.A. have numerous certifications issued by renowned research institutions such as VDE, UL or CSA International

The electromagnetic relays have been certified to comply with the following standards: EN 61810-1 - VDE, UL 508 - Underwriters Laboratories, C22.2 - CSA International, GB14048.5 - China Quality Certification Centre.

Apart from the certifications which prove the safety and high durability of the products, some of Relpol's products have certifications required for applications of relays in special conditions, e.g. Lloyd's Register certification which acknowledges compliance with the requirements for electrotechnical products to be used on vessels and in devices which operate in adverse climatic conditions, or certificates of AUCOTEAM GmbH, Berlin or Railway Institute to confirm meeting of railway requirements.



PRECAUTIONS:

1. Ensure that the parameters of the product described in its specification provide a safety margin for the appropriate operation of the device or system and never use the product in circumstances which exceed the parameters of the product. 2. Never touch any live parts of the device. 3. Ensure that the product has been connected correctly. An incorrect connection may cause malfunction, excessive heating or risk of fire. 4. In case of any risk of any serious material loss or death or injuries of humans or animals, the devices or systems shall be designed so to equip them with double safety system to guarantee their reliable operation.