

Altech Corp.®

Serving the Automation & Control Industry since 1984



UL 508 Manual Motor Controllers V-EA Series



UL508 Listed

UL 489 Miniature Molded Case Circuit Breakers UL Series



UL 1077 Supplementary Protectors UR Series



Doepke

The Altech Selection of Breakers

The Advantages

In today's very competitive marketplace you need reliability, so you need to use circuit breakers that are high quality and technically correct for your application. Altech is a US leader in DIN rail mounted breakers with ratings up to 63A. Only Altech offers DIN rail mounted breakers that meet UL489, UL508 or UL1077 approvals with a short circuit interrupt capacity of up to 10kA. No other manufacturer offers this complete line. This assures you the right product for your application requirements.

UL (AC), DL (DC), V-EA and UR Series Advantages

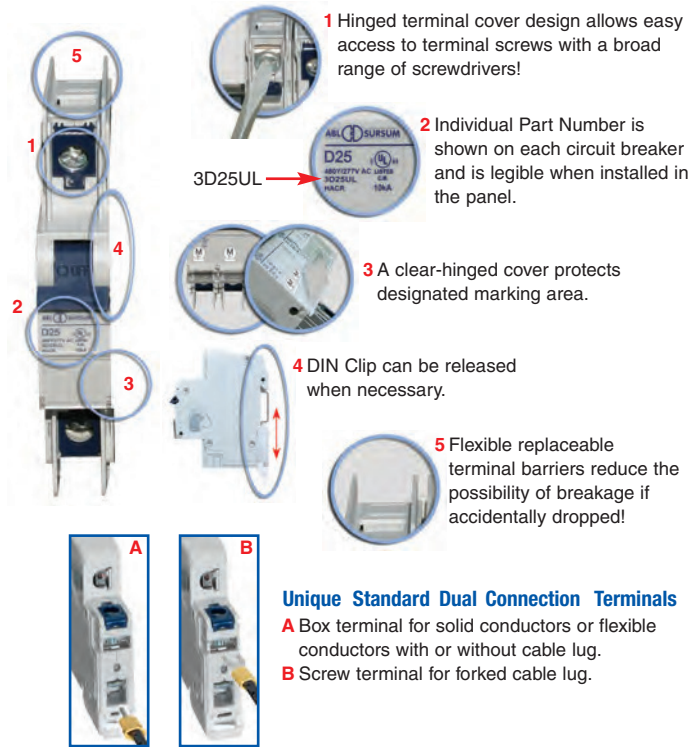

UL 489

UL (AC), DL (DC) Series UL489 Miniature Molded Case Circuit Breakers



IEC 60947-2
Short Circuit Tested

ACCESSORIES

- Auxiliary Contact, Alarm Switch
- Shunt Trip
- Neutral Pole
- Undervoltage Trip (not UL)
- Touch Protection Caps
- Cooling Spacer
- Mounting Screw 34mm
- Lock-out Adapter

UL 489

UL 508

UL 1077

UL 1077
Equipment B breakers

Earth Leakage
Circuit Breakers

ANNEX

UL 508

UM (V-EA) Series UL508 Manual Motor Controllers
 “Suitable as Motor Disconnect”



ACCESSORIES

- Auxiliary Contact, Alarm Switch
- Shunt Trip
- Undervoltage Trip (not UL)
- Neutral Pole
- Touch Protection Caps
- Cooling Spacer
- Mounting Screw 34mm
- Lock-out Adapter**



UL508 Listed
E511762



300600



up to 25A
B,C,D curve



up to 25A
B,C,D curve



UL 1077

**UR Series UL1077 Recognized
Supplementary Protector**



ACCESSORIES

- Auxiliary Contact, Alarm Switch
- Shunt Trip
- Undervoltage Trip (not UL)
- Neutral Pole
- Touch Protection Caps
- Cooling Spacer
- Mounting Screw 34mm
- Lock-out Adapter

**2 series, 5 lines, 3 UL approvals, AC and DC models
and the most trip curves in the industry.**

Altech has the broadest offering in the industry.

Typical UL508A Panel

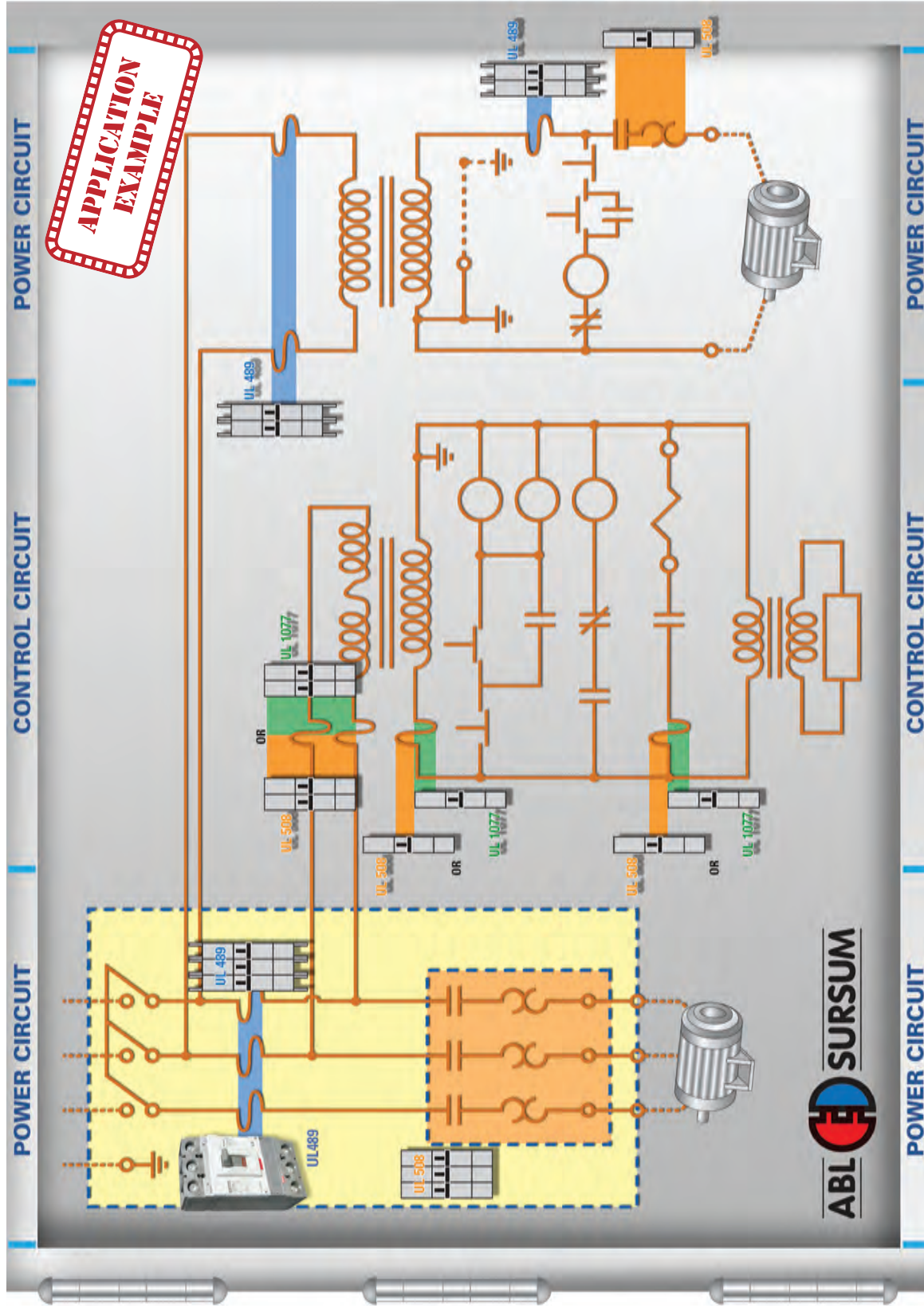

Disclaimer: This is an application example. Installation should be done by a qualified electrician under the guidance of UL/NEC® specifications.

Variation of UL508A Panel

(see NEC® article 430.53 for reference and more information).

APPLICATION EXAMPLE

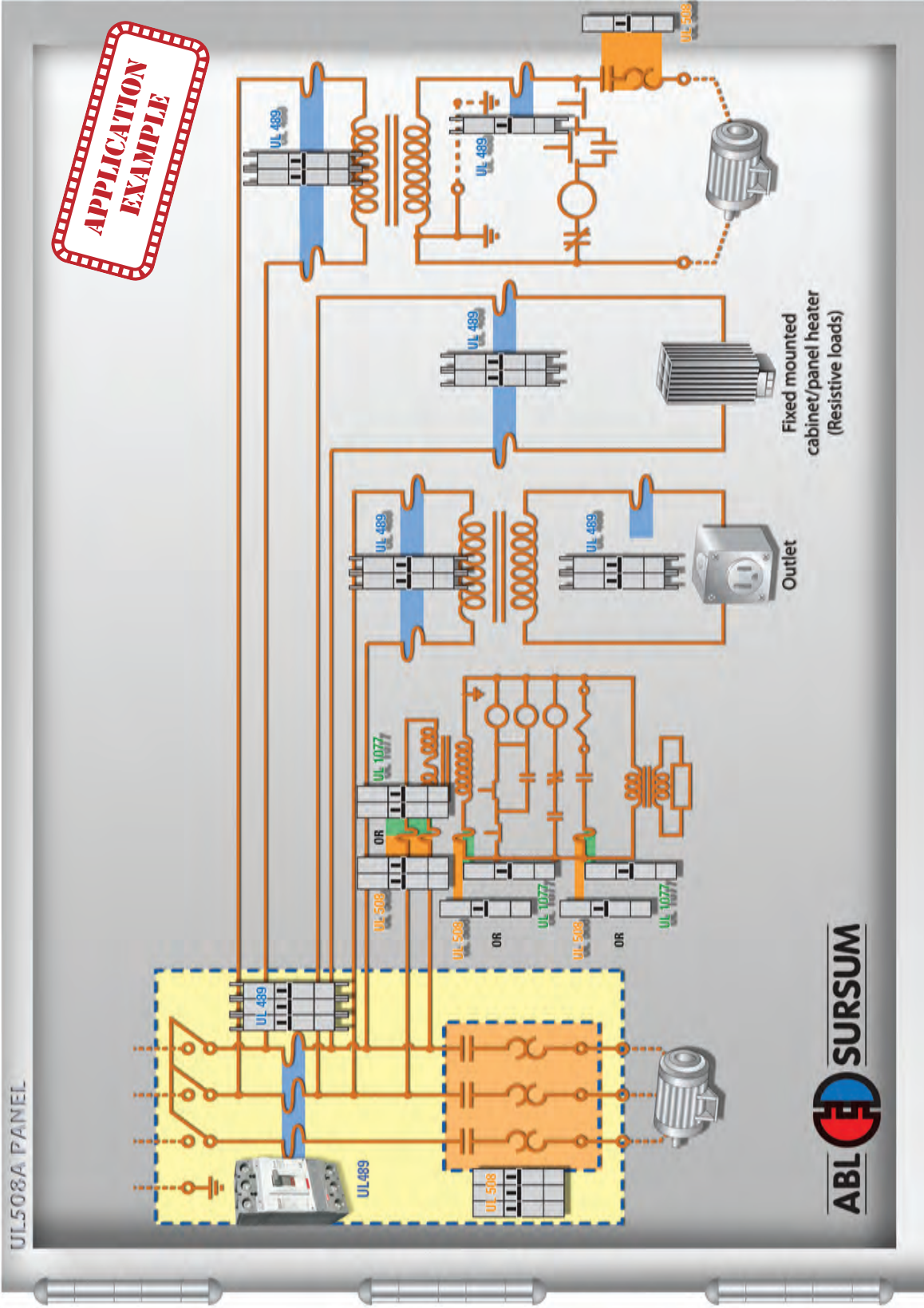

Disclaimer: This is an application example. Installation should be done by a qualified electrician under the guidance of UL/NEC® specifications.

UL 489

UL 508

UL 1077

UL 1077
Equipment Breakers

Earth Leakage
Circuit Breakers

ANNEX

Typical Motor Group Installation

(see NEC® article 430.53 for reference and more information).

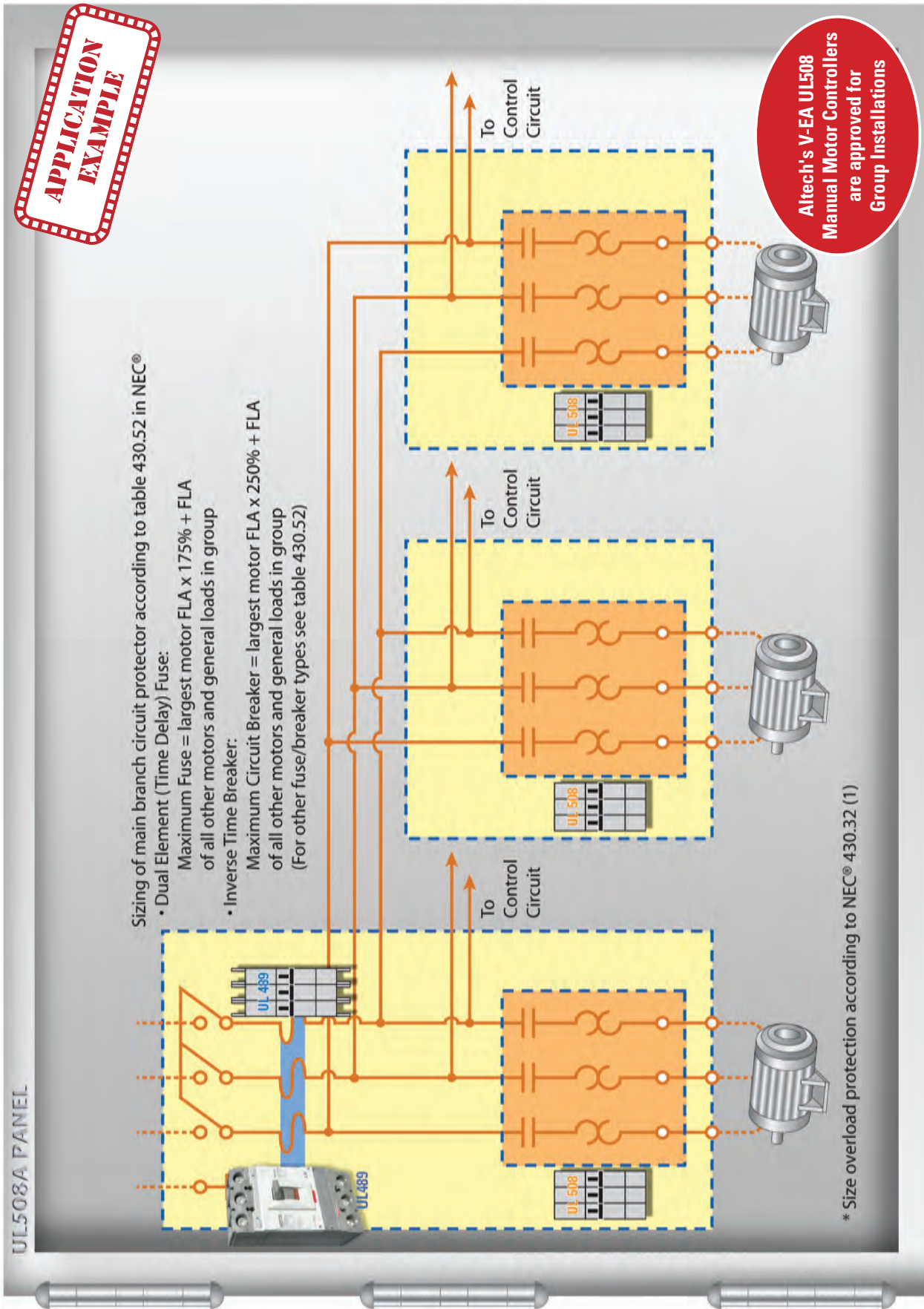

Disclaimer: This is an application example. Installation should be done by a qualified electrician under the guidance of UL/NEC® specifications.

Typical Motor Group Installation

(see NEC® article 430.53 for reference and more information).

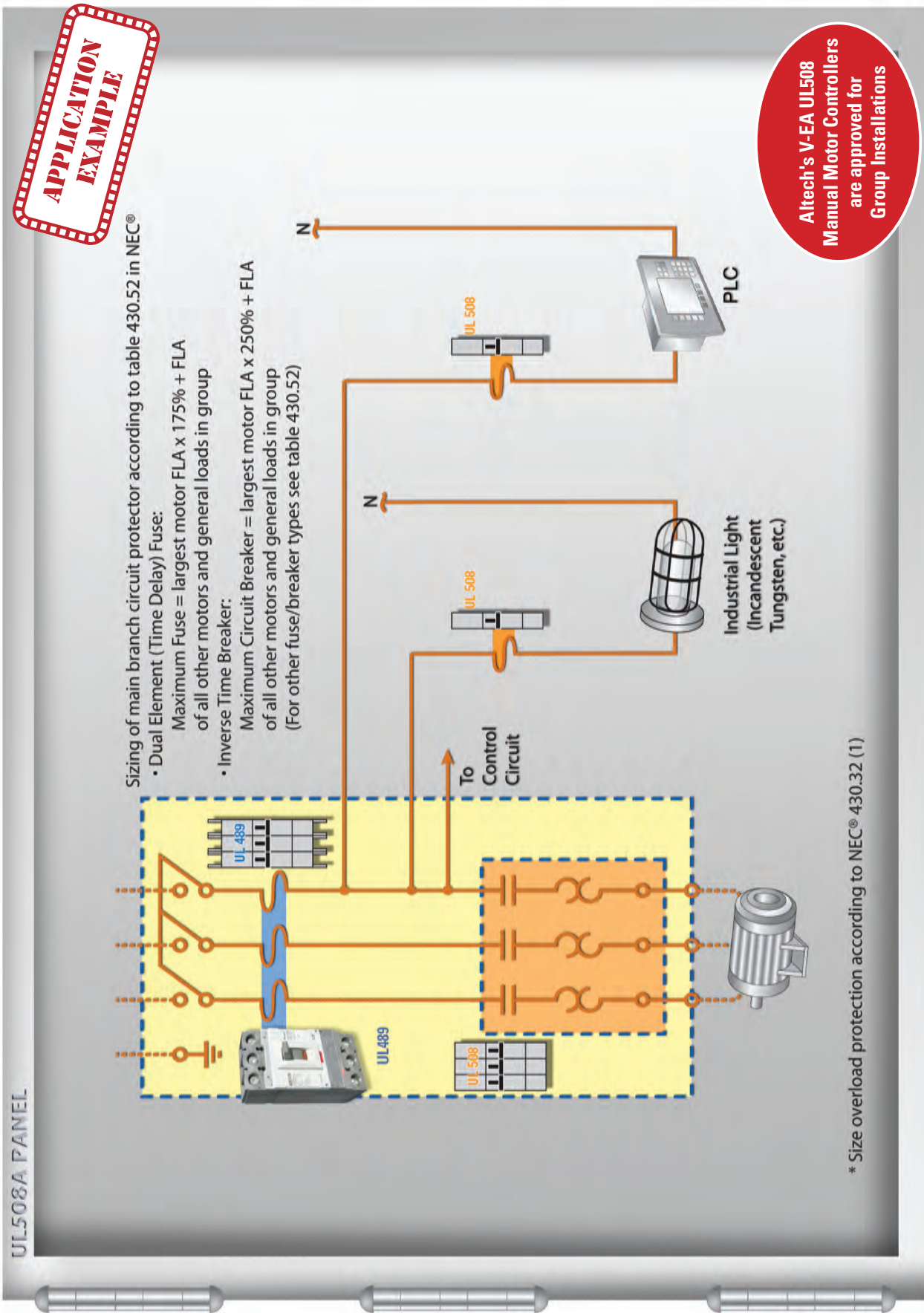

Disclaimer: This is an application example. Installation should be done by a qualified electrician under the guidance of UL/NEC® specifications.

UL 489

UL 508

UL 1077

UL 1077
Equipment Breakers

Earth Leakage
Circuit Breakers

ANNEX

DLS9 Series

UL489 Miniature Molded Case Circuit Breakers

- AC (UL Series) and DC (DL Series)
- DIN Rail Mounted
- 17.5mm width
- Thermal Magnetic
- 240V, 480Y/277V AC, 50/60Hz
- 125V DC (1 pole); 125/250V DC (2 pole)
- 10kA Short Circuit Interrupting Capacity
- HACR Type 40°C
- Line/Load reversible



Current/ Voltage Rating

| | |
|---|---|
| UL-Series | 0.3 - 63A/240V AC, 0.3-32A/480Y/277V AC |
| DL-Series | 0.3 - 63A/125/250V DC |
| Calibration Temperature | 40°C (104°F) |
| Ambient Temperature | -25°C to +70°C (-13°F to 158°F) |
| Storage Temperature | -40°C to +70°C (-40°F to 158°F) |
| Terminal Size Acceptability | Top: 18-3 AWG; Bottom: 18-2 AWG |
| Terminal Torque (min/max) | 2 Nm (17.7 lb.in.) / 2.5Nm (22.2 lb.in) |
| Electrical Life | 6,000 switching cycles ON/ OFF |
| Mechanical Life | 10,000 switching cycles ON/ OFF |
| Vibration Resistance | > 15g according to DIN EN 60069-2-59 during a load with $I_1 = 1.05 \times I_N$ |
| Resistance to mechanical shocks | 25g @ 11ms |
| Degree of protection acc. IEC/EN 60529 | IP20 |
| Mounting Orientation | In any plane |

Short Circuit Interrupting Capacity According to UL 489

| No. Poles | Type | 0.3-32A | 40-63A |
|-----------|------|----------------------------|------------------|
| 1 | AC | 10kA @ 120, 240, 277V | 10kA @ 120, 240V |
| 2-3 | AC | 10kA @ 120, 240, 480Y/277V | 10kA @ 120 240V |

| No. Poles | Type | 0.3-32A | 40-63A |
|-----------|------|-----------------|-----------------|
| 1 | DC | 10kA @ 125V | 10kA @ 125V |
| 2 | DC | 10kA @ 125/250V | 10kA @ 125/250V |

Short Circuit Interrupting Capacity According to IEC 60947-2, DIN EN 60947-2

| No. Poles | Type | 0.3-32 | 40-63A |
|-----------|------|-----------|-----------|
| 1 | AC | 15kA@240V | 15kA@240V |
| 2-3 | AC | 15kA@415V | 10kA@415V |

Marking Details



Dimensions in mm

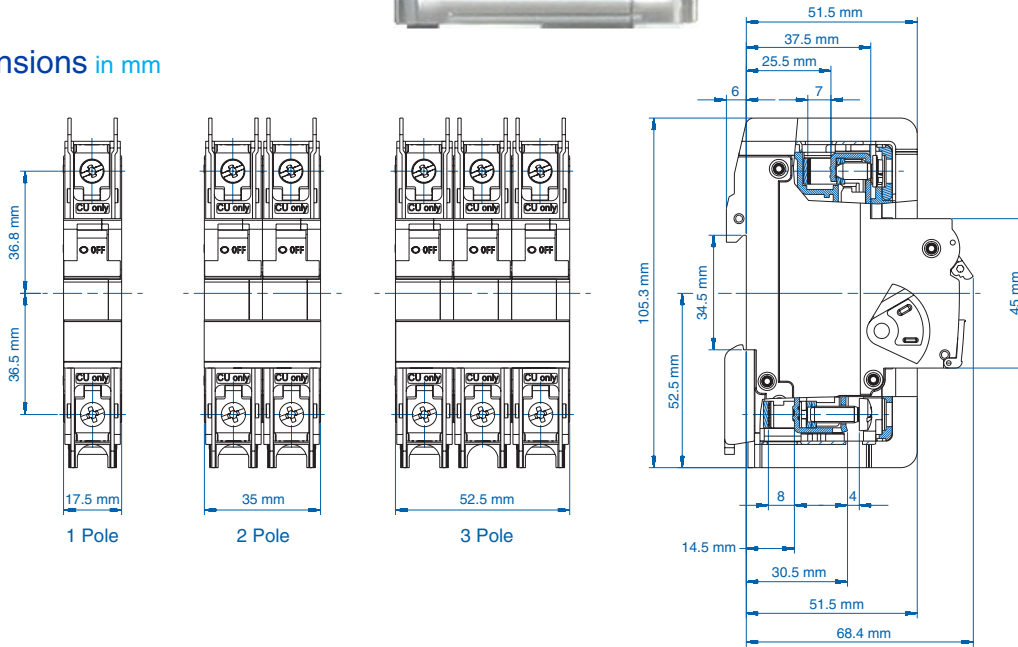

UL 489

UL 508

UL 1077

UL 1077
Equipment Breakers

Earth Leakage
Circuit Breakers

ANNEX

DLS9 Series C-Trip (AC) Characteristic



Application Examples:

Low inrush motors, resistive loads, wiring protection, receptacles, lighting, and control circuit applications. Relatively short thermal trip delay and medium magnetic trip point.



Standard Pack: 12
Weight:
0.3-32A:
1.74kg (3.83lb.)
40-63A:
1.98kg (4.37lb.)

One Pole

| Rated Current | Type/ Cat. No. | Rated Voltage |
|---------------|-------------------|---------------|
| 0.3A | 1C03UL | 277V AC |
| 0.5A | 1C05UL | 277V AC |
| 1.0A | 1C1UL | 277V AC |
| 1.6A | 1C1.6UL | 277V AC |
| 2.0A | 1C2UL | 277V AC |
| 3.0A | 1C3UL | 277V AC |
| 4.0A | 1C4UL | 277V AC |
| 5.0A | 1C5UL | 277V AC |
| 6.0A | 1C6UL | 277V AC |
| 8.0A | 1C8UL | 277V AC |
| 10A | 1C10UL | 277V AC |
| 12A | 1C12UL | 277V AC |
| 13A | 1C13UL | 277V AC |
| 15A | 1C15UL | 277V AC |
| 16A | 1C16UL | 277V AC |
| 20A | 1C20UL | 277V AC |
| 25A | 1C25UL | 277V AC |
| 30A | 1C30UL | 277V AC |
| 32A | 1C32UL | 277V AC |
| 40A | 1C40UL | 240V AC |
| 50A | 1C50UL | 240V AC |
| 60A | 1C60UL | 240V AC |
| 63A | 1C63UL | 240V AC |



Standard Pack: 4
Weight:
0.3-32A:
1.74kg (3.83lb.)
40-63A:
1.98kg (4.37lb.)

Three Pole

| Rated Current | Type/ Cat. No. | Rated Voltage |
|---------------|-------------------|---------------|
| 0.3A | 3C03UL | 480Y/277V AC |
| 0.5A | 3C05UL | 480Y/277V AC |
| 1.0A | 3C1UL | 480Y/277V AC |
| 1.6A | 3C1.6UL | 480Y/277V AC |
| 2.0A | 3C2UL | 480Y/277V AC |
| 3.0A | 3C3UL | 480Y/277V AC |
| 4.0A | 3C4UL | 480Y/277V AC |
| 5.0A | 3C5UL | 480Y/277V AC |
| 6.0A | 3C6UL | 480Y/277V AC |
| 8.0A | 3C8UL | 480Y/277V AC |
| 10A | 3C10UL | 480Y/277V AC |
| 12A | 3C12UL | 480Y/277V AC |
| 13A | 3C13UL | 480Y/277V AC |
| 15A | 3C15UL | 480Y/277V AC |
| 16A | 3C16UL | 480Y/277V AC |
| 20A | 3C20UL | 480Y/277V AC |
| 25A | 3C25UL | 480Y/277V AC |
| 30A | 3C30UL | 480Y/277V AC |
| 32A | 3C32UL | 480Y/277V AC |
| 40A | 3C40UL | 240V AC |
| 50A | 3C50UL | 240V AC |
| 60A | 3C60UL | 240V AC |
| 63A | 3C63UL | 240V AC |



Standard Pack: 6
Weight:
0.3-32A:
1.74kg (3.83lb.)
40-63A:
1.98kg (4.37lb.)

Two Pole

| Rated Current | Type/ Cat. No. | Rated Voltage |
|---------------|-------------------|---------------|
| 0.3A | 2C03UL | 480Y/277V AC |
| 0.5A | 2C05UL | 480Y/277V AC |
| 1.0A | 2C1UL | 480Y/277V AC |
| 1.6A | 2C1.6UL | 480Y/277V AC |
| 2.0A | 2C2UL | 480Y/277V AC |
| 3.0A | 2C3UL | 480Y/277V AC |
| 4.0A | 2C4UL | 480Y/277V AC |
| 5.0A | 2C5UL | 480Y/277V AC |
| 6.0A | 2C6UL | 480Y/277V AC |
| 8.0A | 2C8UL | 480Y/277V AC |
| 10A | 2C10UL | 480Y/277V AC |
| 12A | 2C12UL | 480Y/277V AC |
| 13A | 2C13UL | 480Y/277V AC |
| 15A | 2C15UL | 480Y/277V AC |
| 16A | 2C16UL | 480Y/277V AC |
| 20A | 2C20UL | 480Y/277V AC |
| 25A | 2C25UL | 480Y/277V AC |
| 30A | 2C30UL | 480Y/277V AC |
| 32A | 2C32UL | 480Y/277V AC |
| 40A | 2C40UL | 240V AC |
| 50A | 2C50UL | 240V AC |
| 60A | 2C60UL | 240V AC |
| 63A | 2C63UL | 240V AC |



Add-on Neutral Pole

| Rated Current | Type/ Cat. No. | Rated Voltage |
|---------------|-------------------|---------------|
| 0.3-32A | N32UL | 480/277V AC |
| 40-63A | N63UL | 240V AC |

Standard Pack: 6
Weight:
0.99kg (2.18 lb.)

Standard Dual Connection Terminal

- Box clamp terminals
Top: 18-3 AWG;
Bottom: 18-2 AWG
(Line/Load reversible)
- Ring tongue terminals

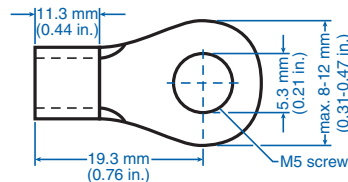
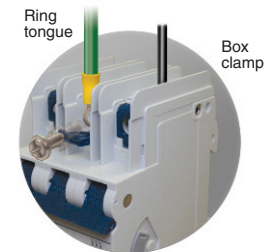

* May differ by manufacturer. Top terminal ring tongue max. thickness 1.6mm.

DLS9 Series
D-Trip (AC)
Characteristic



Application Examples:

High inrush motors, transformers, power supplies, heaters and reactive loads. Relatively long thermal trip delay and very high magnetic trip point.

One Pole



Standard Pack: 12

Weight:
0.3-32A:
1.74kg (3.83lb.)
40-63A:
1.98kg (4.37lb.)

| Rated Current | Type/ Cat. No. | Rated Voltage |
|---------------|-------------------|---------------|
| 0.3A | 1D03UL | 277V AC |
| 0.5A | 1D05UL | 277V AC |
| 1.0A | 1D1UL | 277V AC |
| 1.6A | 1D1.6UL | 277V AC |
| 2.0A | 1D2UL | 277V AC |
| 3.0A | 1D3UL | 277V AC |
| 4.0A | 1D4UL | 277V AC |
| 5.0A | 1D5UL | 277V AC |
| 6.0A | 1D6UL | 277V AC |
| 8.0A | 1D8UL | 277V AC |
| 10A | 1D10UL | 277V AC |
| 12A | 1D12UL | 277V AC |
| 13A | 1D13UL | 277V AC |
| 15A | 1D15UL | 277V AC |
| 16A | 1D16UL | 277V AC |
| 20A | 1D20UL | 277V AC |
| 25A | 1D25UL | 277V AC |
| 30A | 1D30UL | 277V AC |
| 32A | 1D32UL | 277V AC |
| 40A | 1D40UL | 240V AC |
| 50A | 1D50UL | 240V AC |
| 60A | 1D60UL | 240V AC |
| 63A | 1D63UL | 240V AC |

Three Pole



Standard Pack: 4

Weight:
0.3-32A:
1.74kg (3.83lb.)
40-63A:
1.98kg (4.37lb.)

| Rated Current | Type/ Cat. No. | Rated Voltage |
|---------------|-------------------|---------------|
| 0.3A | 3D03UL | 480Y/277V AC |
| 0.5A | 3D05UL | 480Y/277V AC |
| 1.0A | 3D1UL | 480Y/277V AC |
| 1.6A | 3D1.6UL | 480Y/277V AC |
| 2.0A | 3D2UL | 480Y/277V AC |
| 3.0A | 3D3UL | 480Y/277V AC |
| 4.0A | 3D4UL | 480Y/277V AC |
| 5.0A | 3D5UL | 480Y/277V AC |
| 6.0A | 3D6UL | 480Y/277V AC |
| 8.0A | 3D8UL | 480Y/277V AC |
| 10A | 3D10UL | 480Y/277V AC |
| 12A | 3D12UL | 480Y/277V AC |
| 13A | 3D13UL | 480Y/277V AC |
| 15A | 3D15UL | 480Y/277V AC |
| 16A | 3D16UL | 480Y/277V AC |
| 20A | 3D20UL | 480Y/277V AC |
| 25A | 3D25UL | 480Y/277V AC |
| 30A | 3D30UL | 480Y/277V AC |
| 32A | 3D32UL | 480Y/277V AC |
| 40A | 3D40UL | 240V AC |
| 50A | 3D50UL | 240V AC |
| 60A | 3D60UL | 240V AC |
| 63A | 3D63UL | 240V AC |

Two Pole



Standard Pack: 6

Weight:
0.3-32A:
1.74kg (3.83lb.)
40-63A:
1.98kg (4.37lb.)

| Rated Current | Type/ Cat. No. | Rated Voltage |
|---------------|-------------------|---------------|
| 0.3A | 2D03UL | 480Y/277V AC |
| 0.5A | 2D05UL | 480Y/277V AC |
| 1.0A | 2D1UL | 480Y/277V AC |
| 1.6A | 2D1.6UL | 480Y/277V AC |
| 2.0A | 2D2UL | 480Y/277V AC |
| 3.0A | 2D3UL | 480Y/277V AC |
| 4.0A | 2D4UL | 480Y/277V AC |
| 5.0A | 2D5UL | 480Y/277V AC |
| 6.0A | 2D6UL | 480Y/277V AC |
| 8.0A | 2D8UL | 480Y/277V AC |
| 10A | 2D10UL | 480Y/277V AC |
| 12A | 2D12UL | 480Y/277V AC |
| 13A | 2D13UL | 480Y/277V AC |
| 15A | 2D15UL | 480Y/277V AC |
| 16A | 2D16UL | 480Y/277V AC |
| 20A | 2D20UL | 480Y/277V AC |
| 25A | 2D25UL | 480Y/277V AC |
| 30A | 2D30UL | 480Y/277V AC |
| 32A | 2D32UL | 480Y/277V AC |
| 40A | 2D40UL | 240V AC |
| 50A | 2D50UL | 240V AC |
| 60A | 2D60UL | 240V AC |
| 63A | 2D63UL | 240V AC |

Add-on Neutral Pole



| Rated Current | Type/ Cat. No. | Rated Voltage |
|---------------|-------------------|---------------|
| 0.3-32A | N32UL | 480/277V AC |
| 40-63A | N63UL | 240V AC |

Standard Pack: 6

Weight:
0.99kg (2.18 lb.)

Standard Dual Connection Terminal

• Box clamp terminals
Top: 18-3 AWG;
Bottom: 18-2 AWG
(Line/Load reversible)

• Ring tongue terminals

Ring tongue
Box clamp

11.3 mm (0.44 in.)
19.3 mm (0.76 in.)
5.3 mm (0.21 in.)
max. 8-12 mm (0.31-0.47 in.)
M5 screw

* May differ by manufacturer. Top terminal ring tongue max. thickness 1.6mm.

UL 489

UL 508

UL 1077

UL 1077
Equipment Breakers

Earth Leakage
Circuit Breakers

ANNEX

DLS9 Series C-Trip (DC) Characteristic

Application Examples:

Telecommunication equipment,
computer equipment, uninterruptable power supplies.



One Pole

| Rated Current | Type/ Cat. No. | Rated Voltage |
|---------------|-------------------|---------------|
| 0.3A | 1C03DL | 125V DC |
| 0.5A | 1C05DL | 125V DC |
| 1.0A | 1C1DL | 125V DC |
| 1.6A | 1C1.6DL | 125V DC |
| 2.0A | 1C2DL | 125V DC |
| 3.0A | 1C3DL | 125V DC |
| 4.0A | 1C4DL | 125V DC |
| 5.0A | 1C5DL | 125V DC |
| 6.0A | 1C6DL | 125V DC |
| 8.0A | 1C8DL | 125V DC |
| 10A | 1C10DL | 125V DC |
| 12A | 1C12DL | 125V DC |
| 13A | 1C13DL | 125V DC |
| 15A | 1C15DL | 125V DC |
| 16A | 1C16DL | 125V DC |
| 20A | 1C20DL | 125V DC |
| 25A | 1C25DL | 125V DC |
| 30A | 1C30DL | 125V DC |
| 32A | 1C32DL | 125V DC |
| 40A | 1C40DL | 125V DC |
| 50A | 1C50DL | 125V DC |
| 60A | 1C60DL | 125V DC |
| 63A | 1C63DL | 125V DC |

Standard Pack: 12

Weight:
0.3-32A:
1.86kg (4.1lb.)
40-63A:
2.10kg (4.6lb.)

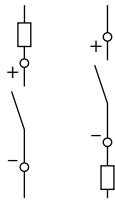

Two Pole

| Rated Current | Type/ Cat. No. | Rated Voltage |
|---------------|-------------------|---------------|
| 0.3A | 2C03DL | 125/250V DC |
| 0.5A | 2C05DL | 125/250V DC |
| 1.0A | 2C1DL | 125/250V DC |
| 1.6A | 2C1.6DL | 125/250V DC |
| 2.0A | 2C2DL | 125/250V DC |
| 3.0A | 2C3DL | 125/250V DC |
| 4.0A | 2C4DL | 125/250V DC |
| 5.0A | 2C5DL | 125/250V DC |
| 6.0A | 2C6DL | 125/250V DC |
| 8.0A | 2C8DL | 125/250V DC |
| 10A | 2C10DL | 125/250V DC |
| 12A | 2C12DL | 125/250V DC |
| 13A | 2C13DL | 125/250V DC |
| 15A | 2C15DL | 125/250V DC |
| 16A | 2C16DL | 125/250V DC |
| 20A | 2C20DL | 125/250V DC |
| 25A | 2C25DL | 125/250V DC |
| 30A | 2C30DL | 125/250V DC |
| 32A | 2C32DL | 125/250V DC |
| 40A | 2C40DL | 125/250V DC |
| 50A | 2C50DL | 125/250V DC |
| 60A | 2C60DL | 125/250V DC |
| 63A | 2C63DL | 125/250V DC |

Standard Pack: 6

Weight:
0.3-32A:
1.86kg (4.1lb.)
40-63A:
2.10kg (4.6lb.)

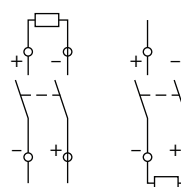

Warning!
Correct polarity must be observed
when connecting the DC circuit breakers.



Standard Dual Connection Terminal

- Box clamp terminals
Top: 18-3 AWG;
Bottom: 18-2 AWG
(Line/Load reversible)
- Ring tongue terminals

11.3 mm (0.44 in.)
5.3 mm (0.21 in.)
max. 8-12 mm (0.31-0.47 in.)
19.3 mm (0.76 in.)
M5 screw

* May differ by manufacturer. Top terminal ring tongue max. thickness 1.6mm.

DLS9 Series D-Trip (DC) Characteristic

Application Examples:

Telecommunication equipment,
computer equipment, uninterruptable power supplies.



One Pole



Standard Pack: 12

Weight:

0.3-32A:
1.86kg (4.1lb.)

40-63A:
2.10kg (4.6lb.)

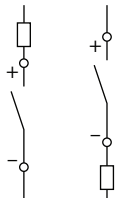

| Rated Current | Type/ Cat. No. | Rated Voltage |
|---------------|-------------------|---------------|
| 0.3A | 1D03DL | 125V DC |
| 0.5A | 1D05DL | 125V DC |
| 1.0A | 1D1DL | 125V DC |
| 1.6A | 1D1.6DL | 125V DC |
| 2.0A | 1D2DL | 125V DC |
| 3.0A | 1D3DL | 125V DC |
| 4.0A | 1D4DL | 125V DC |
| 5.0A | 1D5DL | 125V DC |
| 6.0A | 1D6DL | 125V DC |
| 8.0A | 1D8DL | 125V DC |
| 10A | 1D10DL | 125V DC |
| 12A | 1D12DL | 125V DC |
| 13A | 1D13DL | 125V DC |
| 15A | 1D15DL | 125V DC |
| 16A | 1D16DL | 125V DC |
| 20A | 1D20DL | 125V DC |
| 25A | 1D25DL | 125V DC |
| 30A | 1D30DL | 125V DC |
| 32A | 1D32DL | 125V DC |
| 40A | 1D40DL | 125V DC |
| 50A | 1D50DL | 125V DC |
| 60A | 1D60DL | 125V DC |
| 63A | 1D63DL | 125V DC |

Two Pole



Standard Pack: 6

Weight:

0.3-32A:
1.86kg (4.1lb.)

40-63A:
2.10kg (4.6lb.)

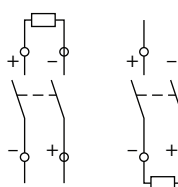

| Rated Current | Type/ Cat. No. | Rated Voltage |
|---------------|-------------------|---------------|
| 0.3A | 2D03DL | 125/250V DC |
| 0.5A | 2D05DL | 125/250V DC |
| 1.0A | 2D1DL | 125/250V DC |
| 1.6A | 2D1.6DL | 125/250V DC |
| 2.0A | 2D2DL | 125/250V DC |
| 3.0A | 2D3DL | 125/250V DC |
| 4.0A | 2D4DL | 125/250V DC |
| 5.0A | 2D5DL | 125/250V DC |
| 6.0A | 2D6DL | 125/250V DC |
| 8.0A | 2D8DL | 125/250V DC |
| 10A | 2D10DL | 125/250V DC |
| 12A | 2D12DL | 125/250V DC |
| 13A | 2D13DL | 125/250V DC |
| 15A | 2D15DL | 125/250V DC |
| 16A | 2D16DL | 125/250V DC |
| 20A | 2D20DL | 125/250V DC |
| 25A | 2D25DL | 125/250V DC |
| 30A | 2D30DL | 125/250V DC |
| 32A | 2D32DL | 125/250V DC |
| 40A | 2D40DL | 125/250V DC |
| 50A | 2D50DL | 125/250V DC |
| 60A | 2D60DL | 125/250V DC |
| 63A | 2D63DL | 125/250V DC |



Warning!

Correct polarity must be observed
when connecting the DC circuit breakers.



Standard Dual Connection Terminal

- Box clamp terminals
Top: 18-3 AWG;
Bottom: 18-2 AWG
(Line/Load reversible)
- Ring tongue terminals

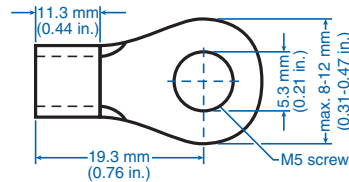
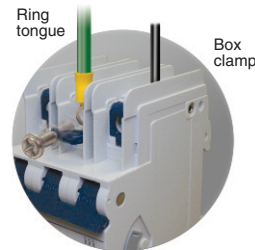

* May differ by manufacturer. Top terminal ring tongue max. thickness 1.6mm.

UL 489

UL 508

UL 1077

UL 1077
Equipment Breakers

Earth Leakage
Circuit Breakers

ANNEX

UL 489

UL 508

UL 1077

UL 1077
Equipment Breakers

Earth Leakage
Circuit Breakers

ANNEX

DLS9 Series Accessories

For mounting instructions please refer to page 61.



Auxiliary Contact, Alarm Switch

| Type/ Cat No. | Description | Contacts Type | Std Pk |
|---------------|------------------------------|--------------------|--------|
| H10UL | 1 Auxiliary Contact | 1NO | 6 |
| H11UL | 2 Auxiliary Contacts | 1NO + 1NC | 6 |
| H12UL | 3 Auxiliary Contacts | 1NO + 2NC | 6 |
| H21UL | 3 Auxiliary Contacts | 2NO + 1NC | 6 |
| HLS11L* | 1 Auxiliary/1 Signal Contact | 1CO + 1CO (Signal) | 6 |

| | |
|---------------------------------|---|
| Rated Operating Currents | 10A@240V AC 3A@110V DC 1A@220V DC |
| Minimum Contact Load | 1mA @ 24V DC |
| Torque | max. 0.8Nm (7 lb.in) |

Wire Range:

| | |
|-----------------------------------|---|
| Single Wire | 1.0mm ² - 2.5mm ² (18-14 AWG) |
| Stranded Wire | 1.0mm ² - 1.5mm ² (18-16 AWG) |
| Stranded Wire with Ferrule | 1.0mm ² - 1.5mm ² (18-16 AWG) |

Shunt Trip

| Type/ Cat No. | Rated Voltage U _N | Max. Operating Current @ U _N | Std Pk |
|---------------|------------------------------|---|--------|
| FA12UL | 12V AC/DC | 1.3A | 5 |
| FA24UL | 24V AC/DC | 0.6A | 5 |
| FA48UL | 48 - 72V AC/DC | 0.2A | 5 |
| FA110UL | 110 - 240V AC/DC, 277V AC | 0.25A @ 110V 0.5A @ 240V 0.58A @ 277V | 5 |

Neutral Pole

| Type/ Cat No. | Rated Current I _N | Rated Voltage U _N | Std Pk |
|---------------|------------------------------|------------------------------|--------|
| N32UL | 0.3 - 32A | 480Y/277V AC | 6 |
| N63UL | 40 - 63A | 240V AC | 6 |

Touch Protection Caps

to cover the terminal screw holes on the switching devices, neutral Poles and shunt trips for increased touch protection.

| Type/ Cat No. | Std Pk |
|---------------|--------|
| BS.UL | 100 |

Cooling Spacer



| Type/ Cat No. | Std Pk |
|---------------|--------|
| 15.960 | 1 |

Mounting Screw 34mm

to connect the auxiliary contact and shunt trip or neutral Pole to the circuit breaker.

| Type/ Cat No. | Std Pk |
|---------------|--------|
| E983419 | 10 |

Lock-out Adapter**



| Type/ Cat No. | Std Pk |
|---------------|--------|
| EASS | 10 |

** UL and DL series can also be locked in the on and off position by simply using a common lead or meter seal, which gets fed through the hole in the handle and a corresponding hole in the housing.

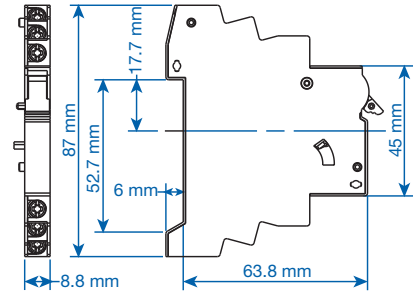

Dimensions HxxUL.

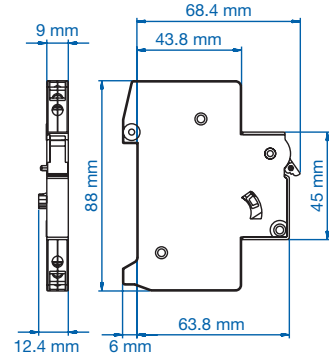

Dimensions HLS11L.

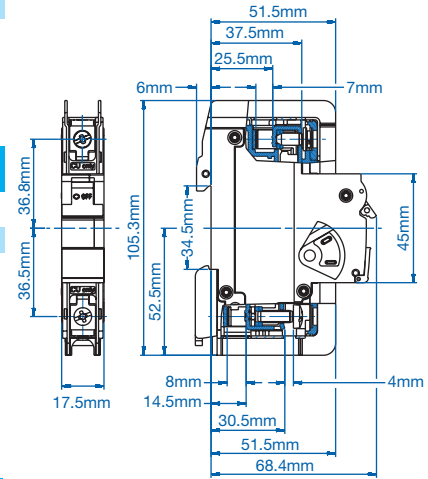

Dimensions NxxUL, FxUL

DLS9 Series (AC) Trip Curves

UL 489

UL 508

UL 1077

UL 1077
Equipment Breakers

Earth Leakage
Circuit Breakers

ANNEX

C (AC) Trip Curve

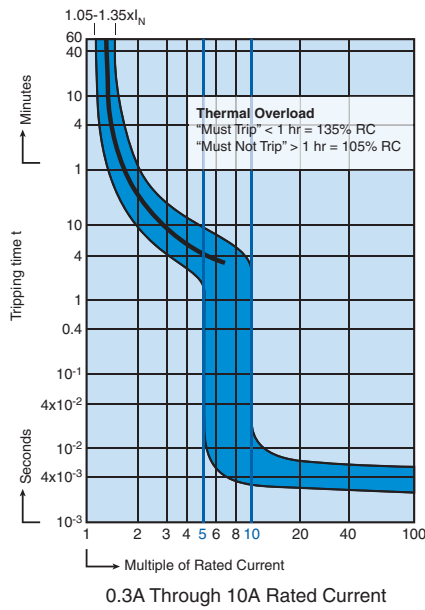

D (AC) Trip Curve

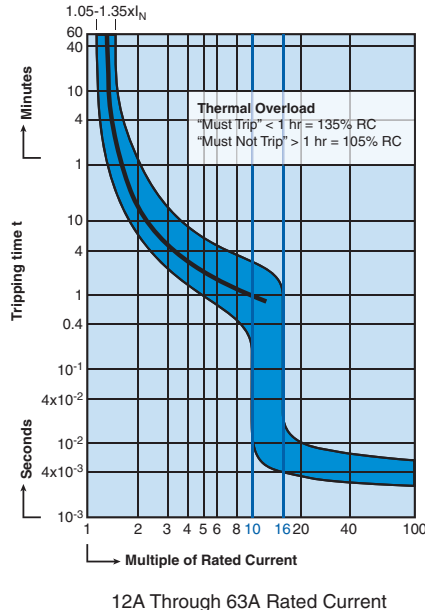
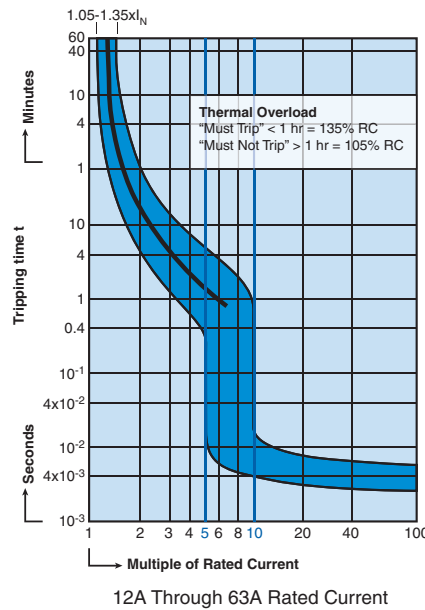
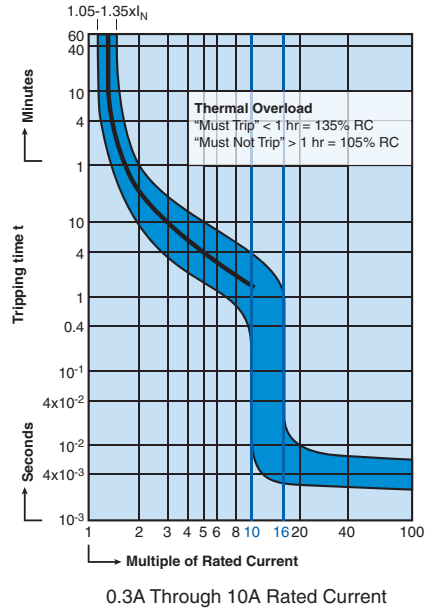

“C” Magnetic Trip Parameters

Rated current 0.3A to 63A.

1. Hold for a minimum of 100ms at surge of 5 times rated current.
2. Trip in under 100ms at 10 times rated current.

“D” Magnetic Trip Parameters

Rated current 0.3A to 63A.

1. Hold for a minimum of 100ms at surge of 10 times rated current.
2. Trip in under 100ms at 16 times rated current.

DLS9 Series (DC) Trip Curves

C (DC) Trip Curve

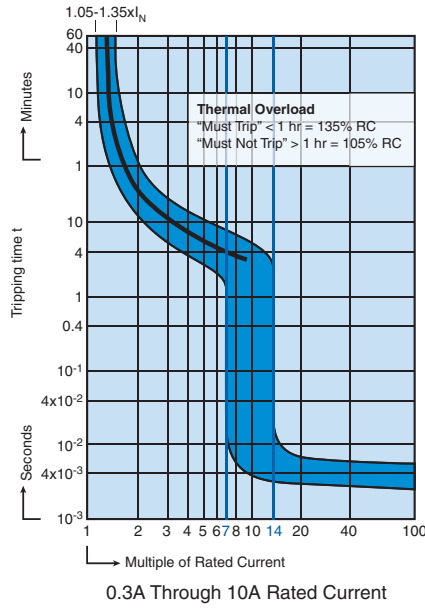

D (DC) Trip Curve

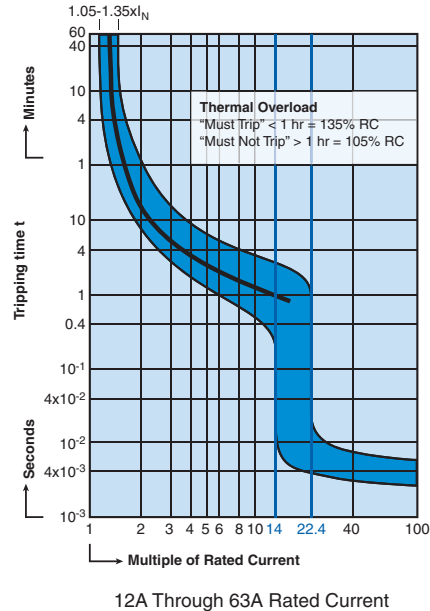
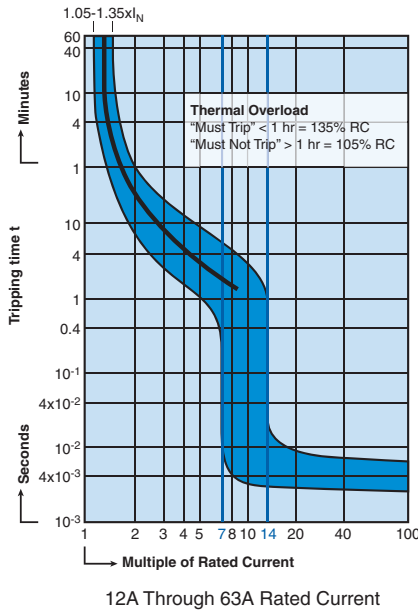
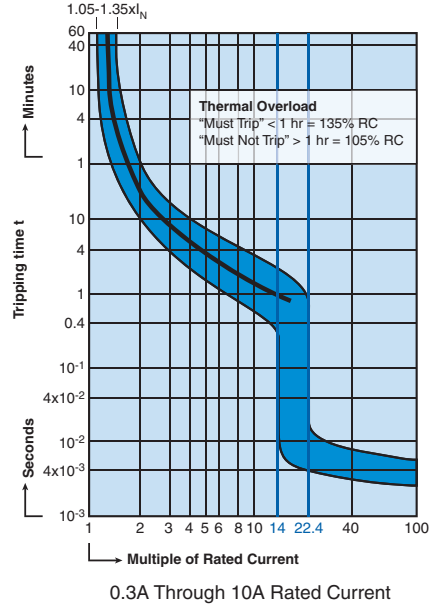

“C” Magnetic Trip Parameters

Rated current 0.3A to 63A.

1. Hold for a minimum of 100ms at surge of 7 times rated current.
2. Trip in under 100ms at 14 times rated current.

“D” Magnetic Trip Parameters

Rated current 0.3A to 63A.

1. Hold for a minimum of 100ms at surge of 14 times rated current.
2. Trip in under 100ms at 22.4 times rated current.

DLS9 Series Internal Resistance

| Rated Current (A) | Trip Characteristic | |
|-------------------|---------------------|---------|
| | C (Ohm) | D (Ohm) |
| 0.3 | 16.8620 | 16.8620 |
| 0.5 | 6.8540 | 6.0009 |
| 1.0 | 1.7000 | 1.7560 |
| 1.6 | 0.5870 | 0.5870 |
| 2.0 | 0.4190 | 0.4190 |
| 3.0 | 0.2020 | 0.2020 |
| 4.0 | 0.1090 | 0.1090 |
| 5.0 | 0.0654 | 0.0654 |
| 6.0 | 0.0528 | 0.0491 |
| 8.0 | 0.0278 | 0.0240 |
| 10 | 0.0216 | 0.0187 |
| 12 | 0.0084 | 0.0085 |
| 13 | 0.0084 | 0.0085 |
| 15/ 16 | 0.0085 | 0.0076 |
| 20 | 0.0067 | 0.0064 |
| 25 | 0.0050 | 0.0041 |
| 30/ 32 | 0.0032 | 0.0027 |
| 40 | 0.0025 | 0.0022 |
| 50 | 0.0019 | 0.0018 |
| 60/ 63 | 0.0018 | 0.0017 |

UL Series Let-through Energy I²t Diagram, D Trip 1 pole

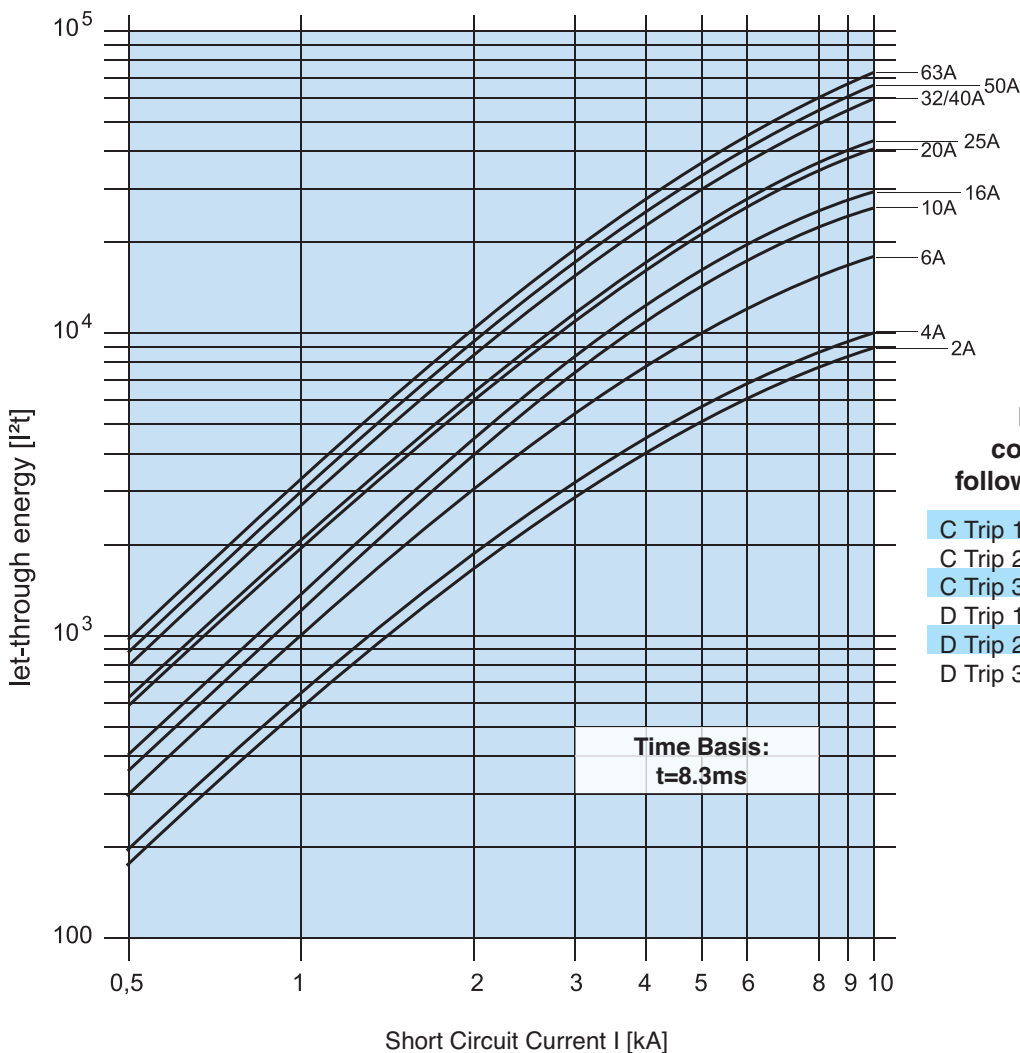

For other Trip/Pole configurations use the following correction factors:

- C Trip 1 pole + 0.84 x curve value
- C Trip 2 pole + 0.71 x curve value
- C Trip 3 pole + 0.92 x curve value
- D Trip 1 pole + 1.00 x curve value
- D Trip 2 pole + 0.87 x curve value
- D Trip 3 pole + 1.08 x curve value

UL 489

UL 508

UL 1077

UL 1077
Equipment Breakers

Earth Leakage
Circuit Breakers

ANNEX

DLS8 Series

UL508 Listed Manual Motor Controllers “Suitable as Motor Disconnect”

- DIN Rail Mounted
- 17.5mm width per pole
- Thermal Magnetic
- 0.3-60A / 480Y/277V AC, 50/60Hz
- 10kA Short Circuit Withstand Capacity
- Applications Include:
 - AC Motor Starting, Across the Line
 - AC General Use
 - AC Resistance
 - AC Discharge Lamps (Ballast)
 - AC Incandescent Lamps (Tungsten)



| | |
|--|---|
| Current/ Voltage Rating | 0.3-60A/480Y/277V AC 0.3-25A: 1 pole - 42V DC; 2 Pole - 80V DC 30-60A: 1 pole - 24V DC; 2 Pole - 60V DC |
| Short Circuit Withstand Rating (UL/CSA - Ratings) | 0.3-60A (RC): 10kA with UL-listed RK5 back-up fuse or MCCB |
| Group Short Circuit Withstand Rating (UL/CSA - Ratings) | 0.3-10A (RC): 10kA; 12-60A (RC): 5kA no branch circuit protection required |
| Interrupting Capacity (VDE - Ratings) | 0.3-63A (RC): 10kA |
| Calibration Temperature | 40°C (104°F) |
| Operating Temperature | -25°C to 55°C (-13°F to 131°F) |
| Storage Temperature | -40°C to 70°C (-40°F to 158°F) |
| Terminal Size Acceptability | Top: 18-3 AWG; Bottom: 18-2 AWG |
| Terminal Torque (min/max) | 2 Nm (17.7 lb.in.) / 2.5Nm (22.2 lb.in) |
| Horse Power Ratings | see page 46 |
| Mechanical Endurance Ratings | see page 47 |
| Vibration Resistance | > 15g according to DIN EN 60069-2-59 during a load with $I_1 = 1.05 \times I_N$ |
| Degree of protection acc. IEC/EN 60529 | IP20 |
| Mounting Orientation | In any plane |

Short Circuit Withstand Ratings for UM (DLS8) Manual Motor Controller

| Trip Curve | Amp Range | Backup Protection | UL-Listed RK5-Fuse up to 10kA | UL-Listed MCCB up to 10kA | No BCP Required up to: |
|------------|-------------|-------------------|-------------------------------|---------------------------|------------------------|
| all | 0.3 - 10A | | 4xRC* min 15A, max 70A | 4xRC* min 15A, max 70A | 10kA |
| all | 12 - 30/32A | | 4xRC* max 125A | 4xRC* max 125A | 5kA |
| all | 40 - 50A | | 4xRC* max 200A | 4xRC* max 200A | 5kA |
| all | 60 / 63A | | 4xRC* max 250A | 4xRC* max 250A | 5kA |

*up to nearest rated current

Marking Details

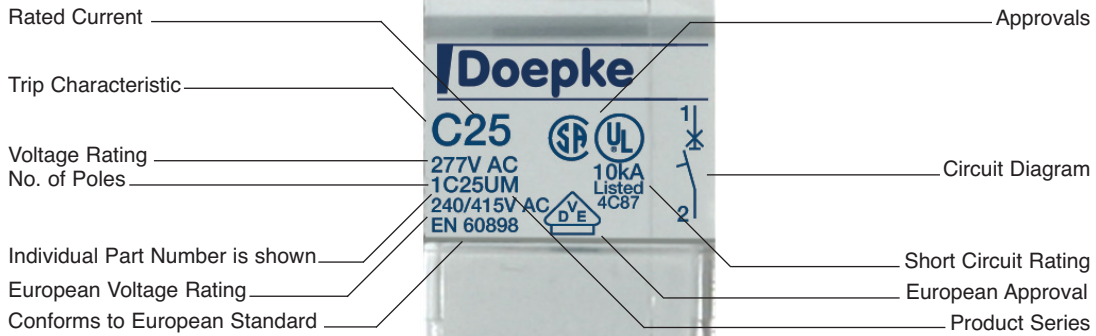

Dimensions in mm

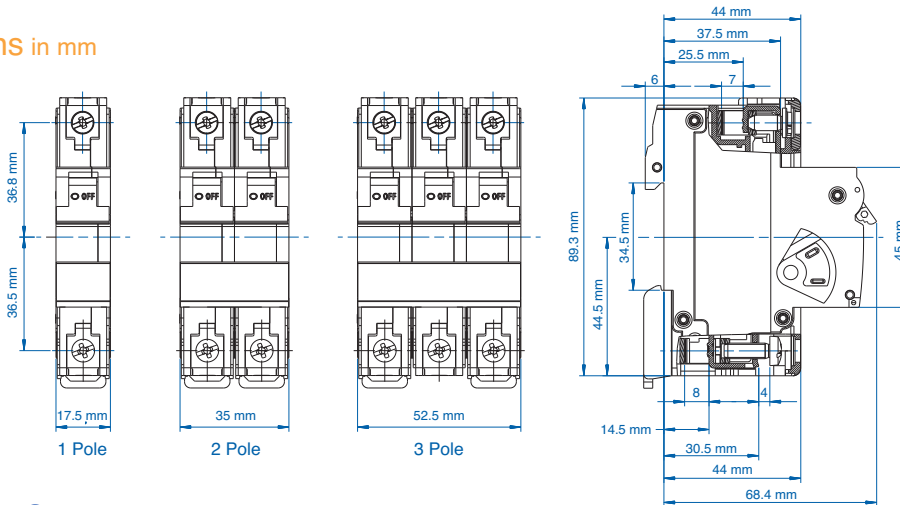

Application Overview

| Trip-Characteristics* | | Applications | | | | | | | | | | | |
|--------------------------------|--------------------|---|-------------------------------------|--------------|------------------------------|---------|---------------|----------------|--------------------|------------------------|----------|--|------------------|
| Characteristic Trip Boundaries | | Lighting Wiring Protection Control Circuits | Business Equipment Appliances | Transformers | Power Supplies Heaters | Motors | | | | General Electronics | Solenoid | Semi- conductors devices with low surge- current and short-circuit withstand capabilities | Reactive Load |
| Thermal Trip | Magnetic Trip | | | | | General | Low Inrush | High Inrush | High Efficiency | | | | |
| Must not Trip >100ms | Must not Trip <1hr | Must not Trip >100ms | Must not Trip at 100ms | | | | | | | | | | |
| B-Characteristics | | | | | | | | | | | | | |
| 1.13xR | 1.45xR | 3xIc | 5xIc | | | | | | | | | | |
| C-Characteristics | | | | | | | | | | | | | |
| 1.13xR | 1.45xR | 5xIc | 10xIc | | | | | | | | | | |
| D-Characteristics | | | | | | | | | | | | | |
| 1.13xR | 1.45xR | 10xB | 16xB | | | | | | | | | | |
| E-Characteristics | | | | | | | | | | | | | |
| 1.05xR | 1.35xR | 14xB | 18xB | | | | | | | | | | |
| G-Characteristics | | | | | | | | | | | | | |
| 1.05xR | 1.35xR | 8xIc | 10xB | | | | | | | | | | |
| Z-Characteristics | | | | | | | | | | | | | |
| 1.05xR | 1.35xR | 2xIc | 3xIc | | | | | | | | | | |

*The value of characteristic is shown in the corresponding heading.



Warning!

This information should only be used as a selection guide. Miniature Circuit Breaker Motor Control in an application with a higher characteristic always requires prototype testing! It is the responsibility of the circuit design engineer to select the appropriate Miniature Circuit Breaker Motor Controller for his specific application.

UL 489

UL 508

UL 1077

UL 1077
Equipment BreakersEarth Leakage
Circuit Breakers

ANNEX

DLS8 Series

B-Trip

Characteristic

Application Examples:

Business equipment, wiring protection, lighting, appliances, control circuits, some motors and some electronic applications. Relatively long thermal trip delay but low magnetic trip point.



E511762



300600

upto 25A
B,C,D curve

Standard Pack: 12

Weight:

0.3A - 32A

1.75kg (3.86 lb.)

40A - 63A

2.07kg (4.56 lb.)

One Pole

| Rated Current | Type/ Voltage | Approvals |
|---------------|------------------|-----------|
| 1.0A | 1B1UM | UL SF |
| 1.6A | 1B1.6UM | UL SF |
| 2.0A | 1B2UM | UL SF |
| 2.5A | 1B2.5UM | UL SF |
| 3.0A | 1B3UM | UL SF |
| 3.5A | 1B3.5UM | UL SF |
| 4.0A | 1B4UM | UL SF |
| 5.0A | 1B5UM | UL SF |
| 6.0A | 1B6UM | UL SF |
| 10A | 1B10UM | UL SF |
| 13A | 1B13UM | UL SF |
| 15A | 1B15UM | UL SF |
| 16A | 1B16UM | UL SF |
| 20A | 1B20UM | UL SF |
| 25A | 1B25UZ | UL SF |
| 30A | 1B30UM | UL SF |
| 32A | 1B32UM | UL SF |
| 40A | 1B40UM | UL SF |
| 50A | 1B50UM | UL SF |
| 60A | 1B60UM | UL SF |
| 63A | 1B63UM | UL SF |



Standard Pack: 4

Weight:

0.3A - 32A

1.75kg (3.86 lb.)

40A - 63A

2.07kg (4.56 lb.)

Three Pole

| Rated Current | Type/ Cat. No. | Approvals |
|---------------|-------------------|-----------|
| 1.0A | 3B1UM | UL SF |
| 1.6A | 3B1.6UM | UL SF |
| 2.0A | 3B2UM | UL SF |
| 2.5A | 3B2.5UM | UL SF |
| 3.0A | 3B3UM | UL SF |
| 3.5A | 3B3.5UM | UL SF |
| 4.0A | 3B4UM | UL SF |
| 5.0A | 3B5UM | UL SF |
| 6.0A | 3B6UM | UL SF |
| 10A | 3B10UM | UL SF |
| 13A | 3B13UM | UL SF |
| 15A | 3B15UM | UL SF |
| 16A | 3B16UM | UL SF |
| 20A | 3B20UM | UL SF |
| 25A | 3B25UM | UL SF |
| 30A | 3B30UM | UL SF |
| 32A | 3B32UM | UL SF |
| 40A | 3B40UM | UL SF |
| 50A | 3B50UM | UL SF |
| 60A | 3B60UM | UL SF |
| 63A | 3B63UM | UL SF |



Standard Pack: 6

Weight:

0.3A - 32A

1.75kg (3.86 lb.)

40A - 63A

2.07kg (4.56 lb.)

Two Pole

| Rated Current | Type/ Cat. No. | Approvals |
|---------------|-------------------|-----------|
| 1.0A | 2B1UM | UL SF |
| 1.6A | 2B1.6UM | UL SF |
| 2.0A | 2B2UM | UL SF |
| 2.5A | 2B2.5UM | UL SF |
| 3.0A | 2B3UM | UL SF |
| 3.5A | 2B3.5UM | UL SF |
| 4.0A | 2B4UM | UL SF |
| 5.0A | 2B5UM | UL SF |
| 6.0A | 2B6UM | UL SF |
| 10A | 2B10UM | UL SF |
| 13A | 2B13UM | UL SF |
| 15A | 2B15UM | UL SF |
| 16A | 2B16UM | UL SF |
| 20A | 2B20UM | UL SF |
| 25A | 2B25UM | UL SF |
| 30A | 2B30UM | UL SF |
| 32A | 2B32UM | UL SF |
| 40A | 2B40UM | UL SF |
| 50A | 2B50UM | UL SF |
| 60A | 2B60UM | UL SF |
| 63A | 2B63UM | UL SF |



Add-on Neutral Pole

| Rated Current | Type/ Cat. No. | Approvals |
|-----------------------|-------------------|-----------|
| 0.3-63A/ 480Y/277V | N63UM | UL SF |

Standard Pack: 6

Weight:

0.775kg (1.71lb.)

DLS8 Series C-Trip Characteristic

Application Examples:

Low inrush motors, lighting, wiring protection, appliances, business equipment, and control circuit applications. Relatively long thermal trip delay and medium magnetic trip point.



Standard Pack: 12

Weight:

0.3A - 32A
1.75kg (3.86 lb.)
40A - 63A
2.07kg (4.56 lb.)

One Pole

| Rated Current | Type/ Cat. No. | Approvals |
|---------------|-------------------|-----------|
| 0.3A | 1C03UM | UL SP |
| 0.5A | 1C05UM | UL SP |
| 0.75A | 1C075UM | UL SP |
| 1.0A | 1C1UM | UL SP |
| 1.6A | 1C1.6UM | UL SP |
| 2.0A | 1C2UM | UL SP |
| 2.5A | 1C2.5UM | UL SP |
| 3.0A | 1C3UM | UL SP |
| 3.5A | 1C3.5UM | UL SP |
| 4.0A | 1C4UM | UL SP |
| 5.0A | 1C5UM | UL SP |
| 6.0A | 1C6UM | UL SP |
| 8.0A | 1C8UM | UL SP |
| 10A | 1C10UM | UL SP |
| 13A | 1C13UM | UL SP |
| 15A | 1C15UM | UL SP |
| 16A | 1C16UM | UL SP |
| 20A | 1C20UM | UL SP |
| 25A | 1C25UM | UL SP |
| 30A | 1C30UM | UL SP |
| 32A | 1C32UM | UL SP |
| 40A | 1C40UM | UL SP |
| 50A | 1C50UM | UL SP |
| 60A | 1C60UM | UL SP |
| 63A | 1C63UM | UL SP |



Standard Pack: 4

Weight:

0.3A - 32A
1.75kg (3.86 lb.)
40A - 63A
2.07kg (4.56 lb.)

Three Pole

| Rated Current | Type/ Cat. No. | Approvals |
|---------------|-------------------|-----------|
| 0.3A | 3C03UM | UL SP |
| 0.5A | 3C05UM | UL SP |
| 0.75A | 3C075UM | UL SP |
| 1.0A | 3C1UM | UL SP |
| 1.6A | 3C1.6UM | UL SP |
| 2.0A | 3C2UM | UL SP |
| 2.5A | 3C2.5UM | UL SP |
| 3.0A | 3C3UM | UL SP |
| 3.5A | 3C3.5UM | UL SP |
| 4.0A | 3C4UM | UL SP |
| 5.0A | 3C5UM | UL SP |
| 6.0A | 3C6UM | UL SP |
| 8.0A | 3C8UM | UL SP |
| 10A | 3C10UM | UL SP |
| 13A | 3C13UM | UL SP |
| 15A | 3C15UM | UL SP |
| 16A | 3C16UM | UL SP |
| 20A | 3C20UM | UL SP |
| 25A | 3C25UM | UL SP |
| 30A | 3C30UM | UL SP |
| 32A | 3C32UM | UL SP |
| 40A | 3C40UM | UL SP |
| 50A | 3C50UM | UL SP |
| 60A | 3C60UM | UL SP |
| 63A | 3C63UM | UL SP |



Standard Pack: 6

Weight:

0.3A - 32A
1.75kg (3.86 lb.)
40A - 63A
2.07kg (4.56 lb.)

Two Pole

| Rated Current | Type/ Cat. No. | Approvals |
|---------------|-------------------|-----------|
| 0.3A | 2C03UM | UL SP |
| 0.5A | 2C05UM | UL SP |
| 0.75A | 2C075UM | UL SP |
| 1.0A | 2C1UM | UL SP |
| 1.6A | 2C1.6UM | UL SP |
| 2.0A | 2C2UM | UL SP |
| 2.5A | 2C2.5UM | UL SP |
| 3.0A | 2C3UM | UL SP |
| 3.5A | 2C3.5UM | UL SP |
| 4.0A | 2C4UM | UL SP |
| 5.0A | 2C5UM | UL SP |
| 6.0A | 2C6UM | UL SP |
| 8.0A | 2C8UM | UL SP |
| 10A | 2C10UM | UL SP |
| 13A | 2C13UM | UL SP |
| 15A | 2C15UM | UL SP |
| 16A | 2C16UM | UL SP |
| 20A | 2C20UM | UL SP |
| 25A | 2C25UM | UL SP |
| 30A | 2C30UM | UL SP |
| 32A | 2C32UM | UL SP |
| 40A | 2C40UM | UL SP |
| 50A | 2C50UM | UL SP |
| 60A | 2C60UM | UL SP |
| 63A | 2C63UM | UL SP |



Add-on Neutral Pole

| Rated Current | Type/ Cat. No. | Approvals |
|-----------------------|-------------------|-----------|
| 0.3-63A/ 480Y/277V | N63UM | UL SP |

Standard Pack: 6

Weight:

0.775kg (1.71lb.)

UL 489

UL 508

UL 1077

UL 1077
Equipment Breakers

Earth Leakage
Circuit Breakers

ANNEX

UL 489

UL 508

UL 1077

UL 1077
Equipment BreakersEarth Leakage
Circuit Breakers

ANNEX

DLS8 Series D-Trip Characteristic

Application Examples:

High inrush motors, transformers, power supplies, heaters and reactive loads.
Relatively long thermal trip delay and very high magnetic trip point.



E511762



300600

upto 25A
B,C,D curve

One Pole

| Rated Current | Type/ Cat. No. | Approvals |
|---------------|-------------------|-----------|
| 0.3A | 1D03UM | UL SF |
| 0.5A | 1D05UM | UL SF |
| 0.75A | 1D075UM | UL SF |
| 1.0A | 1D1UM | UL SF |
| 1.6A | 1D1.6UM | UL SF |
| 2.0A | 1D2UM | UL SF |
| 2.5A | 1D2.5UM | UL SF |
| 3.0A | 1D3UM | UL SF |
| 3.5A | 1D3.5UM | UL SF |
| 4.0A | 1D4UM | UL SF |
| 5.0A | 1D5UM | UL SF |
| 6.0A | 1D6UM | UL SF |
| 8.0A | 1D8UM | UL SF |
| 10A | 1D10UM | UL SF |
| 13A | 1D13UM | UL SF |
| 15A | 1D15UM | UL SF |
| 16A | 1D16UM | UL SF |
| 20A | 1D20UM | UL SF |
| 25A | 1D25UM | UL SF |
| 30A | 1D30UM | UL SF |
| 32A | 1D32UM | UL SF |
| 40A | 1D40UM | UL SF |
| 50A | 1D50UM | UL SF |
| 60A | 1D60UM | UL SF |
| 63A | 1D63UM | UL SF |

Standard Pack: 12

Weight:

0.3A - 32A
1.75kg (3.86 lb.)
40A - 63A
2.07kg (4.56 lb.)



Three Pole

| Rated Current | Type/ Cat. No. | Approvals |
|---------------|-------------------|-----------|
| 0.3A | 3D03UM | UL SF |
| 0.5A | 3D05UM | UL SF |
| 0.75A | 3D075UM | UL SF |
| 1.0A | 3D1UM | UL SF |
| 1.6A | 3D1.6UM | UL SF |
| 2.0A | 3D2UM | UL SF |
| 2.5A | 3D2.5UM | UL SF |
| 3.0A | 3D3UM | UL SF |
| 3.5A | 3D3.5UM | UL SF |
| 4.0A | 3D4UM | UL SF |
| 5.0A | 3D5UM | UL SF |
| 6.0A | 3D6UM | UL SF |
| 8.0A | 3D8UM | UL SF |
| 10A | 3D10UM | UL SF |
| 13A | 3D13UM | UL SF |
| 15A | 3D15UM | UL SF |
| 16A | 3D16UM | UL SF |
| 20A | 3D20UM | UL SF |
| 25A | 3D25UM | UL SF |
| 30A | 3D30UM | UL SF |
| 32A | 3D32UM | UL SF |
| 40A | 3D40UM | UL SF |
| 50A | 3D50UM | UL SF |
| 60A | 3D60UM | UL SF |
| 63A | 3D63UM | UL SF |

Standard Pack: 4

Weight:

0.3A - 32A
1.75kg (3.86 lb.)
40A - 63A
2.07kg (4.56 lb.)



Two Pole

| Rated Current | Type/ Cat. No. | Approvals |
|---------------|-------------------|-----------|
| 0.3A | 2D03UM | UL SF |
| 0.5A | 2D05UM | UL SF |
| 0.75A | 2D075UM | UL SF |
| 1.0A | 2D1UM | UL SF |
| 1.6A | 2D1.6UM | UL SF |
| 2.0A | 2D2UM | UL SF |
| 2.5A | 2D2.5UM | UL SF |
| 3.0A | 2D3UM | UL SF |
| 3.5A | 2D3.5UM | UL SF |
| 4.0A | 2D4UM | UL SF |
| 5.0A | 2D5UM | UL SF |
| 6.0A | 2D6UM | UL SF |
| 8.0A | 2D8UM | UL SF |
| 10A | 2D10UM | UL SF |
| 13A | 2D13UM | UL SF |
| 15A | 2D15UM | UL SF |
| 16A | 2D16UM | UL SF |
| 20A | 2D20UM | UL SF |
| 25A | 2D25UM | UL SF |
| 30A | 2D30UM | UL SF |
| 32A | 2D32UM | UL SF |
| 40A | 2D40UM | UL SF |
| 50A | 2D50UM | UL SF |
| 60A | 2D60UM | UL SF |
| 63A | 2D63UM | UL SF |

Standard Pack: 6

Weight:

0.3A - 32A
1.75kg (3.86 lb.)
40A - 63A
2.07kg (4.56 lb.)



Add-on Neutral Pole

| Rated Current | Type/ Cat. No. | Approvals |
|-----------------------|-------------------|-----------|
| 0.3-63A/ 480Y/277V | N63UM | UL SF |

Standard Pack: 6

Weight:

0.775kg (1.71lb.)

DLS8 Series E-Trip Characteristic

Application Examples:

High efficiency motors, which have exceedingly high inrush currents. Relatively short thermal trip delays and very high magnetic trip points.



Standard Pack: 12
Weight:
0.3A - 32A
1.75kg (3.86 lb.)
40A - 63A
2.07kg (4.56 lb.)

One Pole

| Rated Current | Type/ Cat. No. | Approvals |
|---------------|-------------------|-----------|
| 0.3A | 1E03UM | UL SP |
| 0.5A | 1E05UM | UL SP |
| 0.75A | 1E075UM | UL SP |
| 1.0A | 1E1UM | UL SP |
| 1.6A | 1E1.6UM | UL SP |
| 2.0A | 1E2UM | UL SP |
| 2.5A | 1E2.5UM | UL SP |
| 3.0A | 1E3UM | UL SP |
| 3.5A | 1E3.5UM | UL SP |
| 4.0A | 1E4UM | UL SP |
| 5.0A | 1E5UM | UL SP |
| 6.0A | 1E6UM | UL SP |
| 8.0A | 1E8UM | UL SP |
| 10A | 1E10UM | UL SP |
| 12A | 1E12UM | UL SP |
| 13A | 1E13UM | UL SP |
| 15A | 1E15UM | UL SP |
| 16A | 1E16UM | UL SP |
| 20A | 1E20UM | UL SP |
| 25A | 1E25UM | UL SP |
| 30A | 1E30UM | UL SP |
| 32A | 1E32UM | UL SP |
| 40A | 1E40UM | UL SP |
| 50A | 1E50UM | UL SP |
| 60A | 1E60UM | UL SP |
| 63A | 1E63UM | UL SP |



Standard Pack: 4
Weight:
0.3A - 32A
1.75kg (3.86 lb.)
40A - 63A
2.07kg (4.56 lb.)

Three Pole

| Rated Current | Type/ Cat. No. | Approvals |
|---------------|-------------------|-----------|
| 0.3A | 3E03UM | UL SP |
| 0.5A | 3E05UM | UL SP |
| 0.75A | 3E075UM | UL SP |
| 1.0A | 3E1UM | UL SP |
| 1.6A | 3E1.6UM | UL SP |
| 2.0A | 3E2UM | UL SP |
| 2.5A | 3E2.5UM | UL SP |
| 3.0A | 3E3UM | UL SP |
| 3.5A | 3E3.5UM | UL SP |
| 4.0A | 3E4UM | UL SP |
| 5.0A | 3E5UM | UL SP |
| 6.0A | 3E6UM | UL SP |
| 8.0A | 3E8UM | UL SP |
| 10A | 3E10UM | UL SP |
| 12A | 3E12UM | UL SP |
| 13A | 3E13UM | UL SP |
| 15A | 3E15UM | UL SP |
| 16A | 3E16UM | UL SP |
| 20A | 3E20UM | UL SP |
| 25A | 3E25UM | UL SP |
| 30A | 3E30UM | UL SP |
| 32A | 3E32UM | UL SP |
| 40A | 3E40UM | UL SP |
| 50A | 3E50UM | UL SP |
| 60A | 3E60UM | UL SP |
| 63A | 3E63UM | UL SP |



Standard Pack: 6
Weight:
0.3A - 32A
1.75kg (3.86 lb.)
40A - 63A
2.07kg (4.56 lb.)

Two Pole

| Rated Current | Type/ Cat. No. | Approvals |
|---------------|-------------------|-----------|
| 0.3A | 2E03UM | UL SP |
| 0.5A | 2E05UM | UL SP |
| 0.75A | 2E075UM | UL SP |
| 1.0A | 2E1UM | UL SP |
| 1.6A | 2E1.6UM | UL SP |
| 2.0A | 2E2UM | UL SP |
| 2.5A | 2E2.5UM | UL SP |
| 3.0A | 2E3UM | UL SP |
| 3.5A | 2E3.5UM | UL SP |
| 4.0A | 2E4UM | UL SP |
| 5.0A | 2E5UM | UL SP |
| 6.0A | 2E6UM | UL SP |
| 8.0A | 2E8UM | UL SP |
| 10A | 2E10UM | UL SP |
| 12A | 2E12UM | UL SP |
| 13A | 2E13UM | UL SP |
| 15A | 2E15UM | UL SP |
| 16A | 2E16UM | UL SP |
| 20A | 2E20UM | UL SP |
| 25A | 2E25UM | UL SP |
| 30A | 2E30UM | UL SP |
| 32A | 2E32UM | UL SP |
| 40A | 2E40UM | UL SP |
| 50A | 2E50UM | UL SP |
| 60A | 2E60UM | UL SP |
| 63A | 2E63UM | UL SP |



Add-on Neutral Pole

| Rated Current | Type/ Cat. No. | Approvals |
|-----------------------|-------------------|-----------|
| 0.3-63A/ 480Y/277V | N63UM | UL SP |

Standard Pack: 6
Weight:
0.775kg (1.71lb.)

UL 489

UL 508

UL 1077

UL 1077
Equipment Breakers

Earth Leakage
Circuit Breakers

ANNEX

UL 489

UL 508

UL 1077

UL 1077
Equipment BreakersEarth Leakage
Circuit Breakers

ANNEX

DLS8 Series

G-Trip Characteristic

Application Examples:

General industrial, including motors, some transformers, solenoids, control circuits, lighting and wiring. Meets the US trip norms with relatively short thermal trip delay and high magnetic trip point.



E511762 300600



One Pole

| Rated Current | Type/ Cat. No. | Approvals |
|---------------|-------------------|-----------|
| 0.3A | 1G03UM | UL SF |
| 0.5A | 1G05UM | UL SF |
| 0.8A | 1G08UM | UL SF |
| 1.0A | 1G1UM | UL SF |
| 1.6A | 1G1.6UM | UL SF |
| 2.0A | 1G2UM | UL SF |
| 2.5A | 1G2.5UM | UL SF |
| 3.0A | 1G3UM | UL SF |
| 3.5A | 1G3.5UM | UL SF |
| 4.0A | 1G4UM | UL SF |
| 5.0A | 1G5UM | UL SF |
| 6.0A | 1G6UM | UL SF |
| 8.0A | 1G8UM | UL SF |
| 10A | 1G10UM | UL SF |
| 12A | 1G12UM | UL SF |
| 13A | 1G13UM | UL SF |
| 15A | 1G15UM | UL SF |
| 16A | 1G16UM | UL SF |
| 20A | 1G20UM | UL SF |
| 25A | 1G25UM | UL SF |
| 30A | 1G30UM | UL SF |
| 32A | 1G32UM | UL SF |
| 40A | 1G40UM | UL SF |
| 50A | 1G50UM | UL SF |
| 60A | 1G60UM | UL SF |
| 63A | 1G63UM | UL SF |

Standard Pack: 12

Weight:

0.3A - 32A

1.75kg (3.86 lb.)

40A - 63A

2.07kg (4.56 lb.)



Three Pole

| Rated Current | Type/ Cat. No. | Approvals |
|---------------|-------------------|-----------|
| 0.3A | 3G03UM | UL SF |
| 0.5A | 3G05UM | UL SF |
| 0.8A | 3G08UM | UL SF |
| 1.0A | 3G1UM | UL SF |
| 1.6A | 3G1.6UM | UL SF |
| 2.0A | 3G2UM | UL SF |
| 2.5A | 3G2.5UM | UL SF |
| 3.0A | 3G3UM | UL SF |
| 3.5A | 3G3.5UM | UL SF |
| 4.0A | 3G4UM | UL SF |
| 5.0A | 3G5UM | UL SF |
| 6.0A | 3G6UM | UL SF |
| 8.0A | 3G8UM | UL SF |
| 10A | 3G10UM | UL SF |
| 12A | 3G12UM | UL SF |
| 13A | 3G13UM | UL SF |
| 15A | 3G15UM | UL SF |
| 16A | 3G16UM | UL SF |
| 20A | 3G20UM | UL SF |
| 25A | 3G25UM | UL SF |
| 30A | 3G30UM | UL SF |
| 32A | 3G32UM | UL SF |
| 40A | 3G40UM | UL SF |
| 50A | 3G50UM | UL SF |
| 60A | 3G60UM | UL SF |
| 63A | 3G63UM | UL SF |

Standard Pack: 4

Weight:

0.3A - 32A

1.75kg (3.86 lb.)

40A - 63A

2.07kg (4.56 lb.)



Two Pole

| Rated Current | Type/ Cat. No. | Approvals |
|---------------|-------------------|-----------|
| 0.3A | 2G03UM | UL SF |
| 0.5A | 2G05UM | UL SF |
| 0.8A | 2G08UM | UL SF |
| 1.0A | 2G1UM | UL SF |
| 1.6A | 2G1.6UM | UL SF |
| 2.0A | 2G2UM | UL SF |
| 2.5A | 2G2.5UM | UL SF |
| 3.0A | 2G3UM | UL SF |
| 3.5A | 2G3.5UM | UL SF |
| 4.0A | 2G4UM | UL SF |
| 5.0A | 2G5UM | UL SF |
| 6.0A | 2G6UM | UL SF |
| 8.0A | 2G8UM | UL SF |
| 10A | 2G10UM | UL SF |
| 12A | 2G12UM | UL SF |
| 13A | 2G13UM | UL SF |
| 15A | 2G15UM | UL SF |
| 16A | 2G16UM | UL SF |
| 20A | 2G20UM | UL SF |
| 25A | 2G25UM | UL SF |
| 30A | 2G30UM | UL SF |
| 32A | 2G32UM | UL SF |
| 40A | 2G40UM | UL SF |
| 50A | 2G50UM | UL SF |
| 60A | 2G60UM | UL SF |
| 63A | 2G63UM | UL SF |

Standard Pack: 6

Weight:

0.3A - 32A

1.75kg (3.86 lb.)

40A - 63A

2.07kg (4.56 lb.)



Add-on Neutral Pole

| Rated Current | Type/ Cat. No. | Approvals |
|-----------------------|-------------------|-----------|
| 0.3-63A/ 480Y/277V | N63UM | UL SF |

Standard Pack: 6

Weight:

0.775kg (1.71lb.)

DLS8 Series Z-Trip Characteristic

Application Examples:

Semiconductors, components which fail-short (vs. fail-open), and components/devices with low surge-current and short circuit withstand capabilities. Relatively short thermal delay and very low magnetic trip point.



One Pole

| Rated Current | Type/ Cat. No. | Approvals |
|---------------|-------------------|-----------|
| 0.3A | 1Z03UM | UL SFA |
| 0.5A | 1Z05UM | UL SFA |
| 0.75A | 1Z075UM | UL SFA |
| 1.0A | 1Z1UM | UL SFA |
| 1.6A | 1Z1.6UM | UL SFA |
| 2.0A | 1Z2UM | UL SFA |
| 2.5A | 1Z2.5UM | UL SFA |
| 3.0A | 1Z3UM | UL SFA |
| 3.5A | 1Z3.5UM | UL SFA |
| 4.0A | 1Z4UM | UL SFA |
| 5.0A | 1Z5UM | UL SFA |
| 6.0A | 1Z6UM | UL SFA |
| 8.0A | 1Z8UM | UL SFA |
| 10A | 1Z10UM | UL SFA |
| 12A | 1Z12UM | UL SFA |
| 13A | 1Z13UM | UL SFA |
| 15A | 1Z15UM | UL SFA |
| 16A | 1Z16UM | UL SFA |
| 20A | 1Z20UM | UL SFA |
| 25A | 1Z25UM | UL SFA |
| 30A | 1Z30UM | UL SFA |
| 32A | 1Z32UM | UL SFA |
| 40A | 1Z40UM | UL SFA |
| 50A | 1Z50UM | UL SFA |

Standard Pack: 12

Weight:

0.3A - 32A
1.75kg (3.86 lb.)
40A - 63A
2.07kg (4.56 lb.)



Three Pole

| Rated Current | Type/ Cat. No. | Approvals |
|---------------|-------------------|-----------|
| 0.3A | 3Z03UM | UL SFA |
| 0.5A | 3Z05UM | UL SFA |
| 0.75A | 3Z075UM | UL SFA |
| 1.0A | 3Z1UM | UL SFA |
| 1.6A | 3Z1.6UM | UL SFA |
| 2.0A | 3Z2UM | UL SFA |
| 2.5A | 3Z2.5UM | UL SFA |
| 3.0A | 3Z3UM | UL SFA |
| 3.5A | 3Z3.5UM | UL SFA |
| 4.0A | 3Z4UM | UL SFA |
| 5.0A | 3Z5UM | UL SFA |
| 6.0A | 3Z6UM | UL SFA |
| 8.0A | 3Z8UM | UL SFA |
| 10A | 3Z10UM | UL SFA |
| 12A | 3Z12UM | UL SFA |
| 13A | 3Z13UM | UL SFA |
| 15A | 3Z15UM | UL SFA |
| 16A | 3Z16UM | UL SFA |
| 20A | 3Z20UM | UL SFA |
| 25A | 3Z25UM | UL SFA |
| 30A | 3Z30UM | UL SFA |
| 32A | 3Z32UM | UL SFA |
| 40A | 3Z40UM | UL SFA |
| 50A | 3Z50UM | UL SFA |

Standard Pack: 4

Weight:

0.3A - 32A
1.75kg (3.86 lb.)
40A - 63A
2.07kg (4.56 lb.)



Two Pole

| Rated Current | Type/ Cat. No. | Approvals |
|---------------|-------------------|-----------|
| 0.3A | 2Z03UM | UL SFA |
| 0.5A | 2Z05UM | UL SFA |
| 0.75A | 2Z075UM | UL SFA |
| 1.0A | 2Z1UM | UL SFA |
| 1.6A | 2Z1.6UM | UL SFA |
| 2.0A | 2Z2UM | UL SFA |
| 2.5A | 2Z2.5UM | UL SFA |
| 3.0A | 2Z3UM | UL SFA |
| 3.5A | 2Z3.5UM | UL SFA |
| 4.0A | 2Z4UM | UL SFA |
| 5.0A | 2Z5UM | UL SFA |
| 6.0A | 2Z6UM | UL SFA |
| 8.0A | 2Z8UM | UL SFA |
| 10A | 2Z10UM | UL SFA |
| 12A | 2Z12UM | UL SFA |
| 13A | 2Z13UM | UL SFA |
| 15A | 2Z15UM | UL SFA |
| 16A | 2Z16UM | UL SFA |
| 20A | 2Z20UM | UL SFA |
| 25A | 2Z25UM | UL SFA |
| 30A | 2Z30UM | UL SFA |
| 32A | 2Z32UM | UL SFA |
| 40A | 2Z40UM | UL SFA |
| 50A | 2Z50UM | UL SFA |

Standard Pack: 6

Weight:

0.3A - 32A
1.75kg (3.86 lb.)
40A - 63A
2.07kg (4.56 lb.)



Add-on Neutral Pole

| Rated Current | Type/ Cat. No. | Approvals |
|-----------------------|-------------------|-----------|
| 0.3-63A/ 480Y/277V | N63UM | UL SFA |

Standard Pack: 6

Weight:

0.775kg (1.71lb.)

UL 489

UL 508

UL 1077

UL 1077
Equipment Breakers

Earth Leakage
Circuit Breakers

ANNEX

DLS8 Trip Curves

B Trip Curve

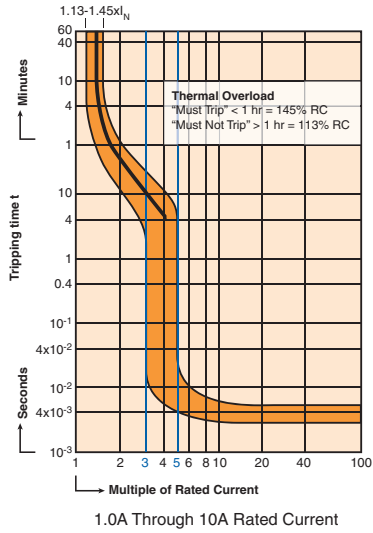

C Trip Curve

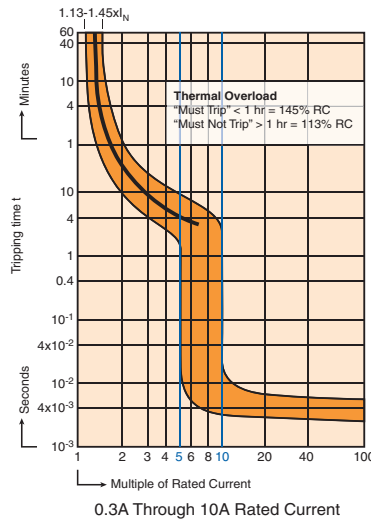

D Trip Curve

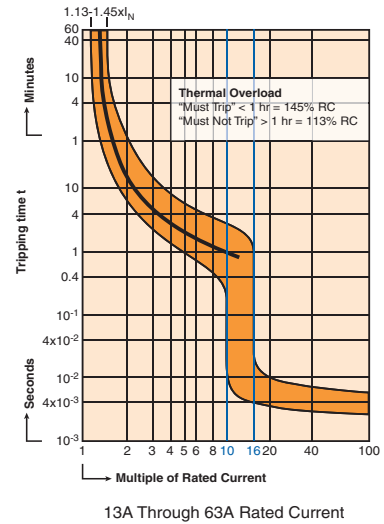
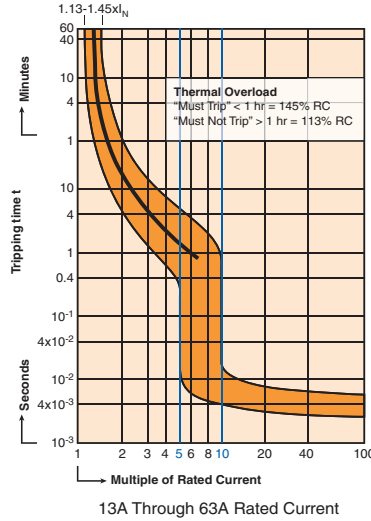
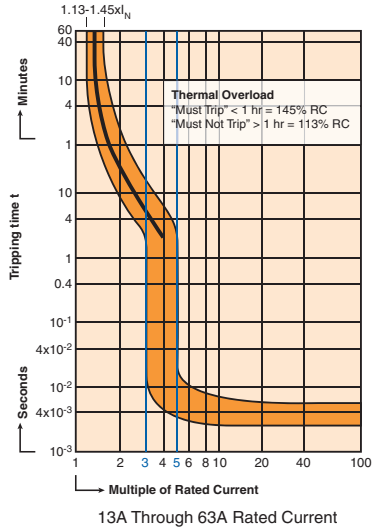
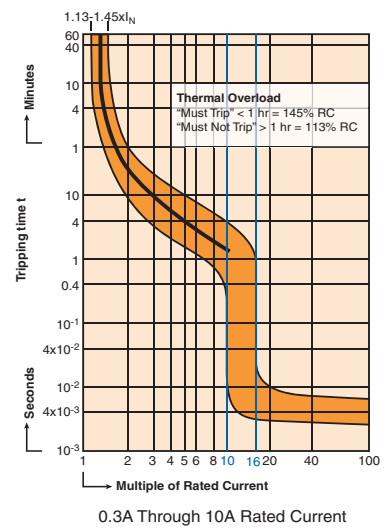

“B” Magnetic Trip Parameters Rated current 1.0A to 63A.

1. Hold for a minimum of 100ms at surge of 3 times rated current.
2. Trip in under 100ms at 5 times rated current.

“C” Magnetic Trip Parameters Rated current 0.3A to 63A.

1. Hold for a minimum of 100ms at surge of 5 times rated current.
2. Trip in under 100ms at 10 times rated current.

“D” Magnetic Trip Parameters Rated current 0.3A to 63A.

1. Hold for a minimum of 100ms at surge of 10 times rated current.
2. Trip in under 100ms at 16 times rated current.

DLS8 Trip Curves

E Trip Curve

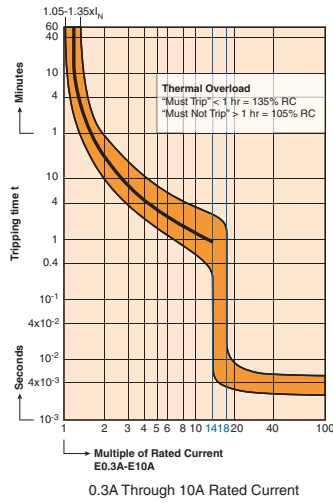

G Trip Curve

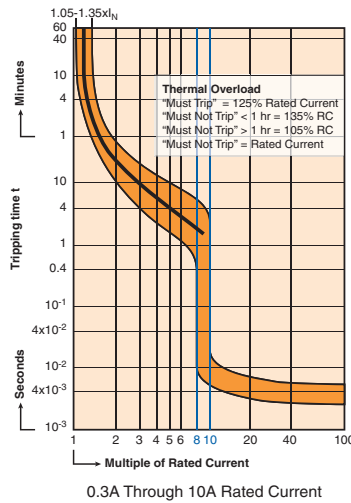

Z Trip Curve

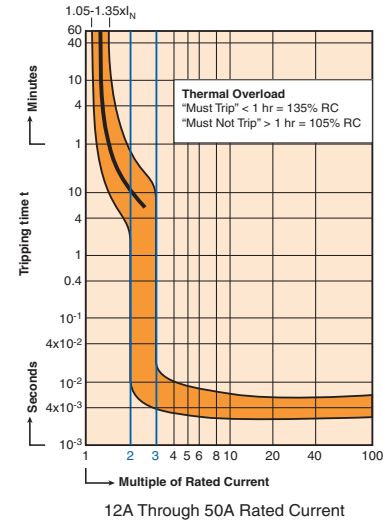
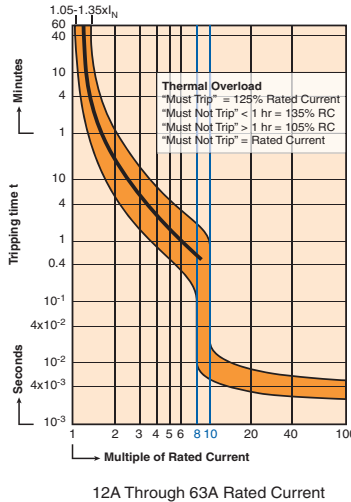
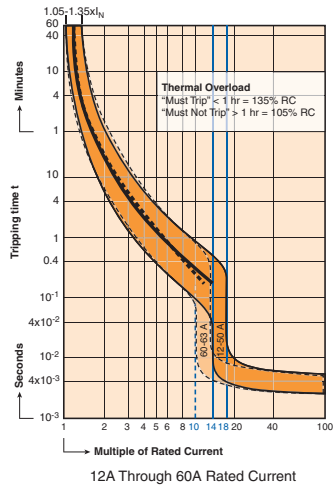
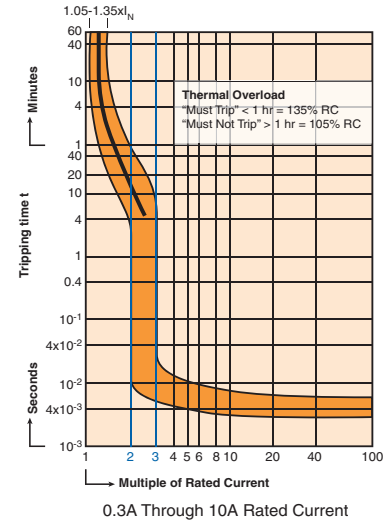

“E” Magnetic Trip Parameters
Rated Current, 0.3A to 50A,
60/63A (dotted line).

Magnetic Trip:

1. Hold for a minimum of 100ms at surge of 14 times (60A, 10 times) rated current.
2. Trip in under 100ms at 18 times (60A, 14 times) rated current.

“G” Magnetic Trip Parameters
Rated Current, 0.3A to 63A.

Magnetic Trip:

1. Hold for a minimum of 100ms at surge of 8 times rated current.
2. Trip in under 100ms at 10 times rated current.

“Z” Trip Parameters
Rated Current, 0.3A to 50A.

Magnetic Trip:

1. Hold for a minimum of 100ms at 2 times rated current.
2. Trip in under 100ms at 3 times rated current.

Table HP 1: AMPERE RATINGS & HORSEPOWER RATING 1 PHASE

| | | | FLA & LRC CONVERTED TO TABLE HORSEPOWER (SEE NOTE #2) USE FLA & LRC RATINGS WHERE NO HP RATING IS GIVEN | | | | | |
|--------------------------|-------------------------|-------------------------|--|-------------------------|-------------------------|-----------------------|-----------------------|-----------------------|
| | | | NOMINAL CIRCUIT VOLTAGE | | | | | |
| DLS8 RATED | MOTOR NAMEPLATE | MOTOR NAMEPLATE | 110-120 VAC | 200 VAC | 208 VAC | 220-240 VAC | 265 VAC | 277 VAC |
| CURRENT (SEE NOTE #1) | FLA RATING | STARTING/ LRC RATING | | | | | | |
| 0.30A 0.50A 0.75A | 0.30A 0.50A 0.75A | 1.80A 3.00A 4.35A | | | | | | |
| 0.80A 1.0A 1.6A | 0.80A 1.0A 1.6A | 4.8A 6.0A 9.6A | | | | | | |
| 2.0A 2.5A 3.0A | 2.0A 2.5A 3.0A | 12.0A 15.0A 18.0A | | 1/6hp 1/6hp | 1/6hp 1/6hp | 1/6hp 1/4hp | 1/6hp 1/4hp | 1/6hp 1/3hp |
| 3.5A 4.0A | 3.5A 4.0A | 21.0A 24.0A | | 1/4hp 1/4hp | 1/4hp 1/3hp | 1/4hp 1/3hp | 1/3hp 1/3hp | 1/3hp 1/3hp |
| 5.0A 6.0A 8.0A | 5.0A 6.0A 8.0A | 30.0A 36.0A 48.0A | 1/6hp 1/4hp 1/3hp | 1/3hp 1/2hp 3/4hp | 1/2hp 1/2hp 3/4hp | 1/2hp 1/2hp 1hp | 1/2hp 3/4hp 1hp | 1/2hp 3/4hp 1hp |
| 10.0A | 10.0A | 60.0A | 1/2hp | 1hp | 1hp | 1 1/2hp | 1 1/2hp | 2hp |
| 12.0A 12.5A | 12.0A 12.5A | 72.0A 75.0A | 1/2hp 1/2hp | 1 1/2hp 1 1/2hp | 1 1/2hp 1 1/2hp | 2hp 2hp | 2hp 2hp | 2hp 2hp |
| 13.0A 15.0A 16.0A | 13.0A 15.0A 16.0A | 78.0A 90.0A 96.0A | 1/2hp 3/4hp 1hp | 1 1/2hp 2hp 2hp | 1 1/2hp 2hp 2hp | 2hp 2hp 2hp | 2hp 3hp 3hp | 2hp 3hp 3hp |
| 20.0A 25.0A | 20.0A 25.0A | 120.0A 150.0A | 1 1/2hp 2hp | 3hp 3hp | 3hp 3hp | 3hp 3hp | 3hp 5hp | 3hp 5hp |
| 30.0A | 30.0A | 180.0A | 2hp | 3hp | 3hp | 5hp | 5hp | 5hp |
| 32.0A | 32.0A | 192.0A | 2hp | 3hp | 5hp | 5hp | 5hp | 5hp |
| 40.0A | 40.0A | 240.0A | 3hp | 5hp | 7 1/2hp | 7 1/2hp | 7 1/2hp | 7 1/2hp |
| 50.0A 60.0A | 50.0A 60.0A | 300.0A 360.0A | 3hp 5hp | 7 1/2hp 10hp | 10hp 10hp | 10hp 10hp | 10hp 10hp | 10hp 15hp |

NOTE #1: For AC motor circuit nameplate full load current, AC general-use loads, AC resistance loads, AC incandescent lamp (tungsten) loads, AC electric discharge lamp (ballast) loads.
NOTE #2: Conversions per UL508® Table 45.2 and NFPA-70: National Electrical Code® 2011 Tables 430-248 and 430-251(A).

TABLE HP 2: AMPERE RATING & HORSEPOWER RATING 3 PHASE & 2 PHASE - 4 WIRE

| FLA & LRC RATINGS CONVERTED TO TABLE HORSEPOWER (SEE NOTE #2) USE FLA & LRC RATINGS WHERE NO HP IS LISTED | | | | | | | | | | | | | |
|--|-------------------------------------|---|-------------------------|-------------------------|-------------------|-------------------|-------------------|-------------------|------------------------------|-----------------------|-------------------------|-------------------------|-------------------------|
| DLS8 RATED CURRENT (SEE NOTE #1) | MOTOR NAMEPLATE FLA RATING | MOTOR NAMEPLATE STARTING/ LRC RATING | 110-120 VAC | | 200 VAC | | 208 VAC | | 220-240 VAC (SEE NOTE #3) | | 440-480 VAC | | |
| | | | Motor Design | | Motor Design | | Motor Design | | Motor Design | | Motor Design | | |
| | | | B, C, D | E | B, C, D | E | B, C, D | E | B, C, D | E | B, C, D | E | |
| 0.30A 0.50A 0.75A | 0.30A 0.50A 0.75A | 3.0A 5.0A 7.5A | | | | | | | | | | | |
| 0.80A 1.0A 1.6A | 0.80A 1.0A 1.6A | 8.0A 10.0A 16.0A | | | | | | | | | | 1/2hp | 1/2hp |
| 2.0A 2.5A 3.0A | 2.0A 2.5A 3.0A | 20.0A 25.0A 30.0A | | | 1/2hp 1/2hp | 1/2hp 1/2hp | 1/2hp 1/2hp | 1/2hp 1/2hp | 1/2hp 1/2hp | 1/2hp 1/2hp | 1/2hp 1/2hp | 1/2hp 1/2hp | 3/4hp 1hp 1 1/2hp |
| 3.5A 4.0A | 3.5A 4.0A | 35.0A 40.0A | | | 1/2hp 3/4hp | 1/2hp 3/4hp | 3/4hp 3/4hp | 3/4hp 3/4hp | 3/4hp 3/4hp | 3/4hp 3/4hp | 3/4hp 3/4hp | 2hp 2hp | 2hp 2hp |
| 5.0A 6.0A 8.0A | 5.0A 6.0A 8.0A | 42.0A 50.4A 67.2A | 1/2hp 1/2hp 3/4hp | 1/2hp 1/2hp 3/4hp | 1hp 1hp 2hp | 1hp 1hp 2hp | 1hp 1hp 2hp | 1hp 1hp 2hp | 1hp 1 1/2hp 2hp | 1hp 1 1/2hp 2hp | 3hp 3hp 5hp | 3hp 3hp 5hp | |
| 10.0A | 10.0A | 84.0A | 1hp | 1hp | 2hp | 2hp | 2hp | 2hp | 3hp | 3hp | 5hp | 5hp | |
| 12.0A 12.5A | 12.0A 12.5A | 100.8A 105.0A | 1 1/2hp 1 1/2hp | 1 1/2hp 1 1/2hp | 3hp 3hp | 3hp 3hp | 3hp 3hp | 3hp 3hp | 3hp 3hp | 3hp 3hp | 7 1/2hp 7 1/2hp | 7 1/2hp 7 1/2hp | |
| 13.0A 15.0A 16.0A | 13.0A 15.0A 16.0A | 109.2A 126.0A 134.4A | 1 1/2hp 2hp 2hp | 1 1/2hp 2hp 2hp | 3hp 3hp 3hp | 3hp 3hp 3hp | 3hp 3hp 3hp | 3hp 3hp 3hp | 3hp 3hp 5hp | 3hp 3hp 5hp | 7 1/2hp 10hp 10hp | 7 1/2hp 10hp 10hp | |
| 20.0A 25.0A | 20.0A 25.0A | 168.0A 210.0A | 3hp 3hp | 3hp 3hp | 5hp 5hp | 5hp 5hp | 5hp 7 1/2hp | 5hp 7 1/2hp | 5hp 7 1/2hp | 5hp 7 1/2hp | 10hp 15hp | 10hp 15hp | |
| 30.0A | 30.0A | 252.0A | 5hp | 5hp | 5hp | 5hp | 7 1/2hp | 7 1/2hp | 10hp | 10hp | 20hp | 20hp | |
| 32.0A | 32.0A | 268.8A | 5hp | 5hp | 5hp | 5hp | 10hp | 10hp | 10hp | 10hp | 20hp | 20hp | |
| 40.0A | 40.0A | 226.0A | 5hp | 5hp | 10hp | 7 1/2hp | 10hp | 7 1/2hp | 10hp | 10hp | 30hp | 20hp | |
| 50.0A 60.0A | 50.0A 60.0A | 282.5A 339.0A | 7 1/2hp 10hp | 7 1/2hp 10hp | 15hp 15hp | 10hp 10hp | 15hp 20hp | 10hp 10hp | 15hp 20hp | 10hp 15hp | 30hp 40hp | 25hp 30hp | |

NOTE #1: For AC motor circuit nameplate full load current, AC general-use loads, AC resistance loads, AC incandescent lamp (tungsten) loads, AC electric discharge lamp (ballast) loads.
NOTE #2: Conversions per UL508® proposed Tables 45.2 and 45.4 and NFPA-70: National Electrical Code® 2011 Tables 430-249, 430-250 and 430-251(B).

DLS8 INTERNAL RESISTANCE

| Rated Current (Amp) | Trip Characteristic | | | | | |
|---------------------|---------------------|----------|----------|----------|----------|----------|
| | B (Ohms) | C (Ohms) | D (Ohms) | E (Ohms) | G (Ohms) | Z (Ohms) |
| 0.3 | — | 16.8620 | 16.8620 | 14.52000 | 16.8620 | 31.5060 |
| 0.5 | — | 6.8540 | 6.0009 | 5.92000 | 6.8540 | 10.2460 |
| 0.75/0.8 | — | 3.0540 | 3.0540 | 2.70000 | 3.0540 | 5.3920 |
| 1.0 | — | 1.7000 | 1.7560 | 1.48000 | 1.7560 | 2.6910 |
| 1.6 | — | 0.5870 | 0.5870 | 0.57400 | 0.5870 | 0.9440 |
| 2.0 | — | 0.4190 | 0.4190 | 0.40500 | 0.4190 | 0.8900 |
| 2.5 | — | 0.2950 | 0.2950 | 0.26900 | 0.2950 | 0.4290 |
| 3.0 | — | 0.2020 | 0.2020 | 0.18600 | 0.2020 | 0.3460 |
| 3.5 | — | 0.1390 | 0.1390 | 0.13900 | 0.1390 | 0.1790 |
| 4.0 | — | 0.1090 | 0.1090 | 0.10600 | 0.1090 | 0.1620 |
| 5.0 | — | 0.0654 | 0.0654 | 0.05900 | 0.0654 | 0.1050 |
| 6.0 | 0.0528 | 0.0528 | 0.0491 | 0.04600 | 0.0491 | 0.0823 |
| 8.0 | — | 0.0278 | 0.0240 | 0.03040 | 0.0333 | 0.0371 |
| 10 | 0.0216 | 0.0216 | 0.0187 | 0.02020 | 0.0211 | 0.0278 |
| 12/12.5 | — | — | — | 0.00724 | 0.0084 | 0.0151 |
| 13 | 0.0113 | 0.0084 | 0.0085 | 0.00724 | 0.0084 | 0.0151 |
| 15/16 | 0.0085 | 0.0085 | 0.0076 | 0.00731 | 0.0076 | 0.0114 |
| 20 | 0.0067 | 0.0067 | 0.0064 | 0.00582 | 0.0064 | 0.0075 |
| 25 | 0.0050 | 0.0050 | 0.0041 | 0.00411 | 0.0046 | 0.0050 |
| 30/32 | 0.0032 | 0.0032 | 0.0027 | 0.00272 | 0.0030 | 0.0032 |
| 40 | 0.0025 | 0.0025 | 0.0022 | 0.00212 | 0.0022 | 0.0022 |
| 50 | 0.0019 | 0.0019 | 0.0018 | 0.00184 | 0.0019 | 0.00195 |
| 60/63 | 0.0018 | 0.0018 | 0.0017 | 0.00172 | 0.00179 | — |

Resistances listed are “hot” values, as opposed to cold start values. Operating voltage drop across the DLS8 and power loss per pole can be approximated with basic formulas:

$$V_{DROD} = I_{OPERATING} \times R_{TABLE}$$

$$P_{LOSS P/P} = I^2_{OPERATING} \times R_{TABLE}$$

Voltage drops should be reviewed when DLS8s with high internal resistance are used (e.g., load voltage minimums). Power loss should be reviewed when DLS8s with high rated currents are used (e.g., enclosure heating).

The listed DLS8 internal resistance values should not be used in calculations of available short-circuit current downstream of the DLS8. The dynamic impedance of the DLS8 under short-circuit conditions can vary significantly from internal resistance values in normal operation.

LINE CURRENT FREQUENCY EFFECTS ON TRIP CURVES

| Frequency Effects on Magnetic Trip Curves | | | | | |
|---|-----------------------------------|----------------------------|----------------------------|----------------------------|------------------------|
| Trip Curve | Trip Zone At 16 2/3 - 60Hz (x RC) | Trip Zone At 100 Hz (x RC) | Trip Zone At 200 Hz (x RC) | Trip Zone At 400 Hz (x RC) | Trip Zone At DC (x RC) |
| Z | 2 - 3 | 2.2 - 3.3 | 2.4 - 3.6 | 2.8 - 4.2 | 3.0 - 4.5 |
| B | 3 - 5 | 3.3 - 5.5 | 3.6 - 6.0 | 4.2 - 7.0 | 4.5 - 7.5 |
| C | 5 - 10 | 5.5 - 11.0 | 6.0 - 12 | 7.0 - 14.0 | 7.5 - 15.0 |
| G | 8 - 10 | 8.8 - 11.0 | 9.6 - 12.0 | 11.2 - 14.0 | 12.0 - 15.0 |
| D | 10 - 16 | 11.0 - 17.6 | 12.0 - 19.2 | 14.0 - 22.4 | 15.0 - 24.0 |
| E | 14 - 18 | 15.4 - 19.8 | 16.8 - 21.6 | 19.6 - 25.2 | 21.0 - 27.0 |

The thermal trip is not affected by the frequency of the line current. The magnetic trip is within the trip zone of the characteristic curve for frequencies from 16 2/3 to 60Hz. At lower and higher frequencies, the magnetic trip will be delayed longer than indicated by the characteristic curve, roughly as follows:

- At 100Hz:** Mag. Trip Current = 1.1 x curve current
- At 200Hz:** Mag. Trip Current = 1.2 x curve current
- At 400Hz:** Mag. Trip Current = 1.4 x curve current
- At DC:** Mag. Trip Current = 1.5 x curve current

For example, at 16 2/3 - 60 Hz the magnetic trip zone for the “G” characteristic is 8 to 10 times the rated current of the specific DLS8 (i.e., hold for at least 100ms at 8 x RC, trip in less than 100ms at 10 x RC). With a 400Hz current, a magnetic trip at 10 x RC would be greatly delayed (thermal would likely trip first), as the magnetic trip zone is now 11.2 to 14 x RC. If a quicker magnetic trip is required with 400Hz, the “B” or “C” characteristic should be considered.

MECHANICAL ENDURANCE RATINGS (ON/OFF OPERATIONS)

| Application | 2 x (1.15 x RC) | 2 x RC | RC | No Load | Total |
|---|--------------------------------------|--------|-------|---------|--------|
| AC General Use | — | 6,000 | — | 4,000 | 10,000 |
| AC Motor Starting Across the Line | 1,000 | — | 5,000 | 4,000 | 10,000 |
| AC Incandescent Lamps (Tungsten) | — | — | 6,000 | 4,000 | 10,000 |
| AC Electrical Discharge Lamps (Ballast) | — | 6,000 | — | 4,000 | 10,000 |
| AC Resistance | — | 6,000 | — | 4,000 | 10,000 |
| Manufacturers self certification | 20000 ON/OFF operations with no load | | | | |

MA-Series

Three Phase Adjustable Trip Miniature Circuit Breakers/ Manual Motor Controllers

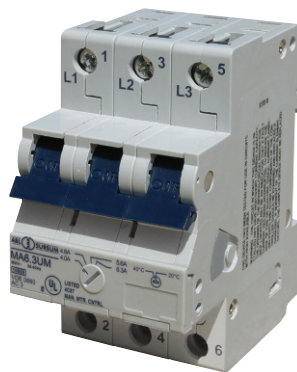

 E511762

 CAN/CSA-C22.2 No.14 certified

The MA was designed to handle the high inrush loads of 3 phase transformers, power supplies, motors, etc. The MA protects wiring and equipment from damage caused by the three major classes of over-current, yet greatly reduces the number of nuisance trips in high starting and inrush current circuits.

An IEC device with excellent ratings under a UL listing at 480Y/277V (including group ratings) and at 500V under international standards, the Altech/ABL Sursum MA provides short and long term cost effective circuit protection for USA and/or export applications. The short term advantages include: (1) adjustable thermal trip allows finalization of initial designs before procurement of the load equipment is complete; (2) snap-on mounting for readily available, internationally standardized DIN Rail saves panel layout design time as well as installation and change labor; (3) large cage-clamp terminals with screws suitable to power screwdrivers, simplifies and speeds wiring; (4) convenient switched disconnect during factory testing and/or initial start-up saves time and aggravation. The key long term advantage is customer satisfaction and proven over-current protection of wiring and equipment (and the lack of rework/repair costs).

Type Designation

| | | | |
|-----|-----|-----|-----|
| MA | 16 | U | M |
| (a) | (b) | (c) | (d) |

- (a) = MA - Manual Motor Controller
 (b) = Rated Current
 (c) = U - US Housing
 = R - US Housing + Ring Tongue
 (d) = M - Part No. Designation

| | |
|---|---|
| Voltage Rating | 480Y/277V AC |
| AIC (Interrupt Capacity) | 0.16A-2.5A: 42kA; 4.0A-16A: 14kA; 20A-40A: 10kA |
| Standard Short Circuit Withstand Rating (UL/CSA Ratings) | 0.16A-2.5A: 42kA; 4.0A-16A: 14kA; 20A-40A: 10kA |
| Group Short Circuit Ratings (UL/CSA Ratings) | see above |
| Typical Life | 6,000 on/off operations with 2xRC |
| Calibration Temperature | 25°C, +0°, -5° (77°F, +0° -9°) |
| Standard Pack and Weight | 1/450g (1.0 lb.) |
| Terminal Size Acceptability | Top/Bottom: 18-3 AWG |
| Terminal Torque (min/max) | 2 Nm (17.7 lb.in.) / 2.5Nm (22.2 lb.in) |

| Cat. No. | Rated Current | FLA Dial Adjustment Markings | GROUP SHORT CIRCUIT RATING AT 480VAC ^a (and BCP size) | 3Ø HORSEPOWER RATINGS AT NOMINAL LINE VOLTAGE (See Note for HEA Definition) | | | | |
|----------|---------------|------------------------------|--|---|---------------|---------------|-------------------|-------------------|
| | | | | 110-120V HP (HEA) | 200V HP (HEA) | 208V HP (HEA) | 220-240V HP (HEA) | 460-480V HP (HEA) |
| MA016UM | 0.16A | 0.1/ 0.12/0.14/0.16 | 42kARMS symmetrical (max. 1200A MCCB or RK5) | | | | | |
| MA025UM | 0.25A | 0.16/0.19/0.22/0.25 | | | | | | |
| MA040UM | 0.40A | 0.25/0.30/0.35/0.40 | | | | | | |
| MA063UM | 0.63A | 0.40/0.48/0.56/0.63 | | | | | | |
| MA1.0UM | 1.0A | 0.63/0.75/0.87/1.0 | | | | | | |
| MA1.6UM | 1.6A | 1.0/1.2/1.4/1.6 | | | | | | |
| MA2.5UM | 2.5A | 1.6/1.9/2.2/2.5 | | | | | | |
| MA4.0UM | 4.0A | 2.5/3.0/3.5/4.0 | 14kARMS | 1/2 (4.0) | 3/4 (3.2) | 3/4 (3.1) | 1 (3.6) | 2 (3.42) |
| MA6.3UM | 6.3A | 4.0/4.8/5.6/6.3 | symmetrical (max. 350A MCCB or RK5) | 3/4 (5.6) | 1 1/2 (6.0) | 1 1/2 (5.7) | 1 1/2 (5.2) | 3 (4.8) |
| MA10UM | 10A | 6.3/7.5/8.7/10 | | 1 (7.2) | 2 (7.8) | 2 (7.5) | 3 (9.6) | 5 (7.6) |
| MA16UM | 16A | 10/12/14/16 | | 2 (13.6) | 3 (11.0) | 3 (10.6) | 5 (15.2) | 10 (14.0) |
| MA20UM | 20A | 16/17/18.5/20 | 10kARMS | 3 (19.2) | 5 (17.5) | 5 (16.7) | 5 (15.2) | 10 (14.0) |
| MA25UM | 25A | 20/21.5/23/25 | symmetrical (max. 350A MCCB or RK5) | 3 (19.2) | 5 (17.5) | 7 1/2 (24.2) | 7 1/2 (22.0) | 15 (21.0) |
| MA32UM | 32A | 25/27/30/32 | | 5 (30.4) | 7 1/2 (25.0) | 7 1/2 (24.2) | 10 (28.0) | 20 (27.0) |
| MA40UM | 40A | 32/34/37/40 | | 5 (30.4) | 10 (32.0) | 10 (31.0) | 10 (28.0) | 25 (34.0) |

Note: HEA - Horsepower Equivalent Amperes, the nominal amperage assigned to standard motor horsepower ratings in design guide tables such as NFPA-70 Tables 430-248, 430-249, 430-250; UL1077 Table 16.2; CSA - C22.2 No. 235-M89 Tables 44 and 45; CSA-C22.2 No. 14-M91 Table 19, etc. Multiply HEA values (in parenthesis) by 1.1 if power factor is 90%, and by 1.2 if power factor is 80%.

^a The standard-circuit short-circuit rating is 14kA for all types. Group ratings can be used in a standard circuit (e.g., MA1.0U at 42kA), but a higher standard rating cannot be used in a group circuit (e.g., MA40U at 14kA only in standard circuit.)

Dimensions in mm

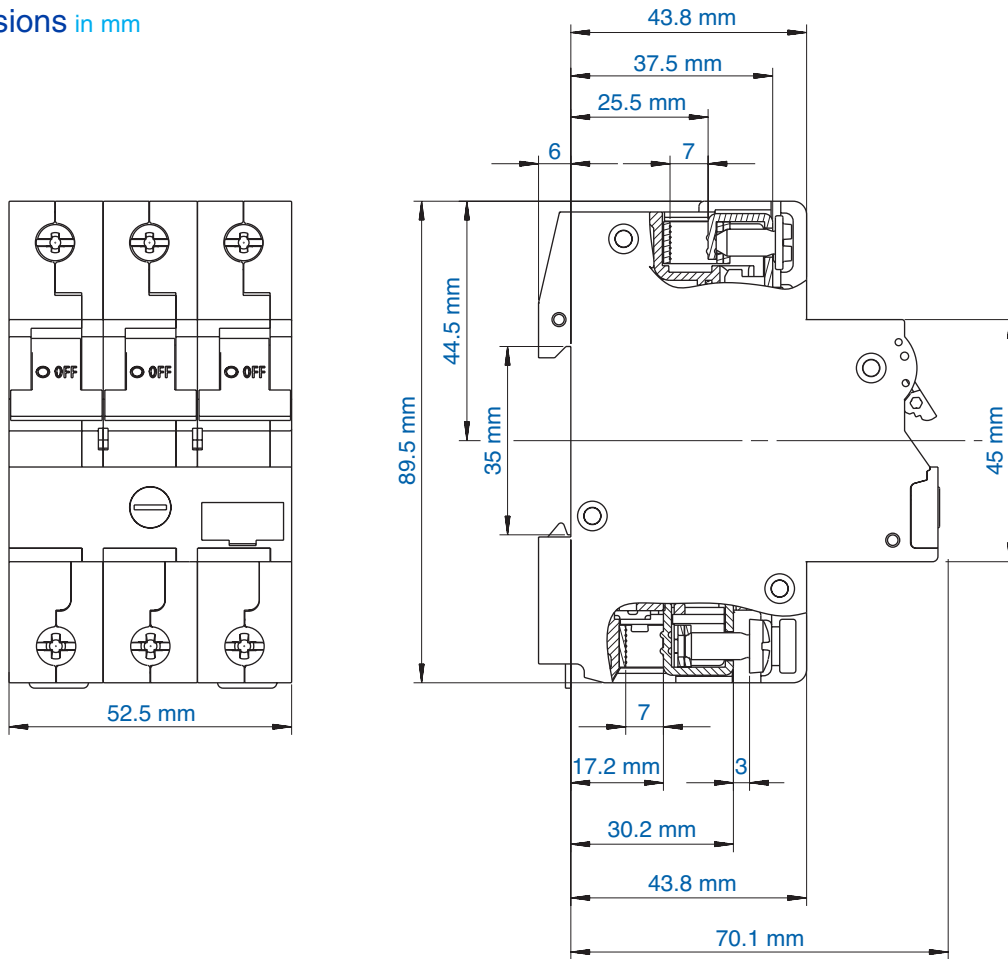

MA- Series Trip Curves

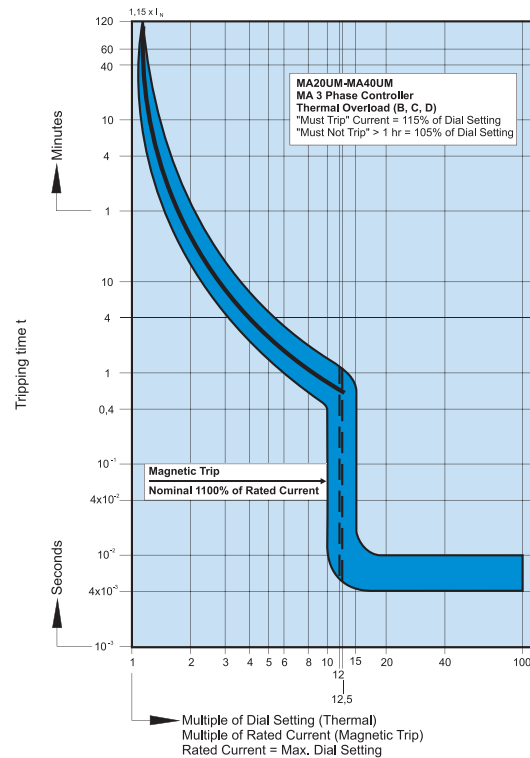
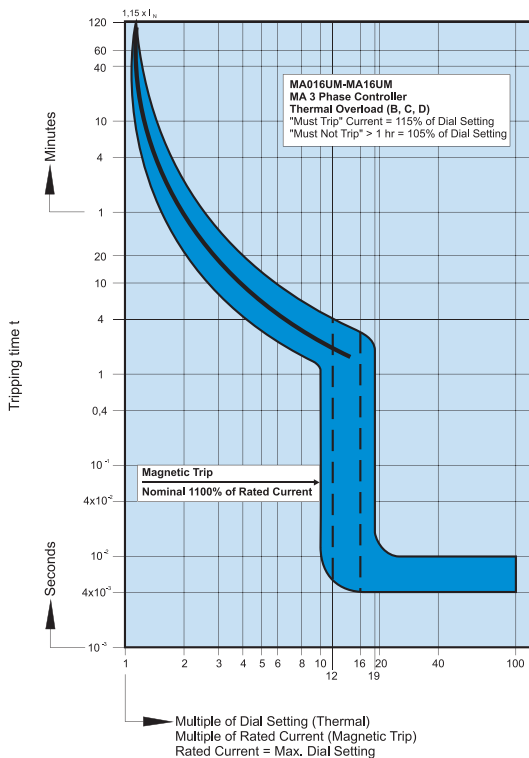

MA/USA Manual Motor Controller

UM (DLS8) and MA Accessories

For mounting instructions please refer to page 61.



Auxiliary Contact, Alarm Switch



| Type/ Cat No. | Description | Contacts Type | Std Pk |
|---------------|-------------------------------|--------------------|--------|
| H10UM | 1 Auxiliary Contact | 1NO | 6 |
| H11UM | 2 Auxiliary Contacts | 1NO + 1NC | 6 |
| H12UM | 3 Auxiliary Contacts | 1NO + 2NC | 6 |
| H21UM | 3 Auxiliary Contacts | 2NO + 1NC | 6 |
| HLS11M* | 1 Auxiliary/1 Signal Contacts | 1CO + 1CO (Signal) | 6 |

| | |
|---------------------------------|---|
| Rated Operating Currents | 10A@240V AC 3A@110V DC 1A@220V DC |
| Minimum Contact Load | 1mA @ 24V DC |
| Torque | max. 0.8Nm (7 lb.in) |

Wire Range:

| | |
|-----------------------------------|---|
| Single Wire | 1.0mm ² - 2.5mm ² (18-14 AWG) |
| Stranded Wire | 1.0mm ² - 1.5mm ² (18-16 AWG) |
| Stranded Wire with Ferrule | 1.0mm ² - 1.5mm ² (18-16 AWG) |

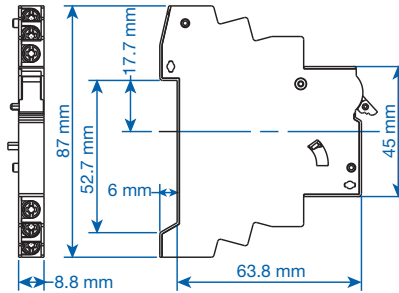

Dimensions HxxUM.



Shunt Trip

| Type/ Cat No. | Rated Voltage U _N | Max. Operating Current @ U _N | Std Pk |
|---------------|------------------------------|---|--------|
| FA12UM | 12V AC/DC | 1.3A | 5 |
| FA24UM | 24V AC/DC | 0.6A | 5 |
| FA48UM | 48 - 72V AC/DC | 0.2A | 5 |
| FA110UM | 110 - 240V AC/DC, 277V AC | 0.25A @ 110V 0.5A @ 240V 0.58A @ 277V | 5 |

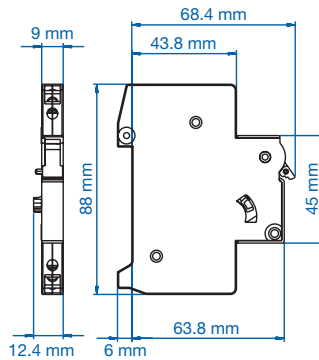

Dimensions HLS11M.

UL 489

UL 508

UL 1077

UL 1077
Equipment Breakers

Earth Leakage
Circuit Breakers

ANNEX

UM (DLS8) and MA Accessories

For mounting instructions please refer to page 61.



Neutral Pole

| Type/ Cat No. | Rated Current I _N | Rated Voltage U _N | Std Pk |
|---------------|------------------------------|------------------------------|--------|
| N63UM | 0.3 - 63A | 480Y/277V AC | 6 |

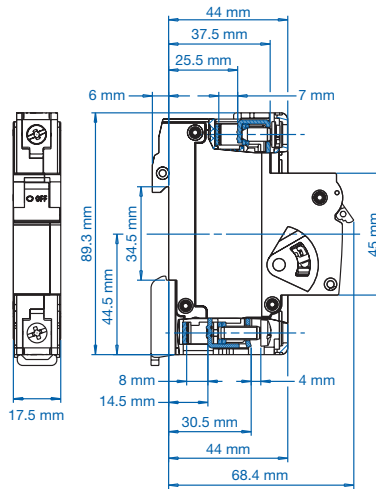

Dimensions N63UM, FAxxUM.



Touch Protection Caps

to cover the terminal screw holes on the switching devices, neutral Poles and shunt trips for increased touch protection.

| Type/ Cat No. | Std Pk |
|---------------|--------|
| BS.UL | 100 |

Cooling Spacer



| Type/ Cat No. | Std Pk |
|---------------|--------|
| 15.960 | 1 |



Mounting Screw 34mm

to connect the auxiliary contact and shunt trip or neutral Pole to the circuit breaker.

| Type/ Cat No. | Std Pk |
|---------------|--------|
| E983419 | 10 |



Lock-out Adapter**

| Type/ Cat No. | Std Pk |
|---------------|--------|
| EASS | 10 |

** UM (DLS8) and MA can also be locked in the on and off position by simply using a common lead or meter seal, which gets fed through the hole in the handle and a corresponding hole in the housing.

UL 489

UL 508

UL 1077

UL 1077
Equipment Breakers

Earth Leakage
Circuit Breakers

ANNEX

DLS7 Series

UL1077 Recognized Supplementary Protector

- DIN Rail Mounted
- 17.5mm width per pole
- Thermal Magnetic
- 0.5-60A / 480Y/277V AC, 50/60Hz
- 10kA Short Circuit Withstand Capacity
- Applications (on the load side of Branch Circuit Protection) include: Sensitive Electronics, Power Supplies, Appliance circuits, etc.



| | |
|---|---|
| UR - Series | 0.5-60A / 480Y/277V AC |
| Voltage Rating | 0.5 - 10A (RC): 10 kA with no back-up fuse |
| Short Circuit Withstand Rating | 8 - 63A (RC): 10 kA with UL-listed Class J back-up fuse; 5 kA with no back-up fuse |
| Calibration Temperature | 30°C (86°F) |
| Ambient Temperature | -25°C to +70°C (-13°F to 158°F) |
| Storage Temperature | -40°C to +70°C (-40°F to 158°F) |
| Terminal Torque (min/max) | 2 Nm (17.7 lb.in.) / 2.5Nm (22.2 lb.in) |
| Electrical Life | 6,000 switching cycles ON/ OFF |
| Mechanical Life | 10,000 switching cycles ON/ OFF |
| Vibration Resistance | > 15g according to DIN EN 60069-2-59 during a load with $1.05 \times I_N$ |
| Resistance to mechanical shocks | 25g @ 11ms |
| Degree of protection acc. IEC/EN 60529 | IP20 |
| Mounting Orientation | In any plane |

Short Circuit Withstand Ratings for R-Series Supplementary Protector

| Trip Curve | Amp Range | Backup Protection | |
|------------|-----------|-----------------------------------|--------------------------------|
| | | UL-Listed Class J Fuse up to 10kA | No Backup Fuse Required up to: |
| All | 0.5 - 10A | 70A | 10kA |
| All | 12 - 60A | 4xRC* | 5kA |

*up to nearest rated current

Marking Details

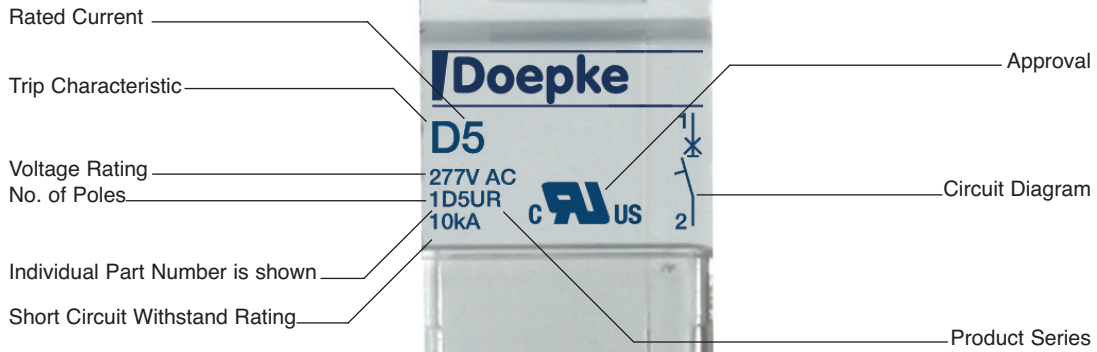

Dimensions in mm

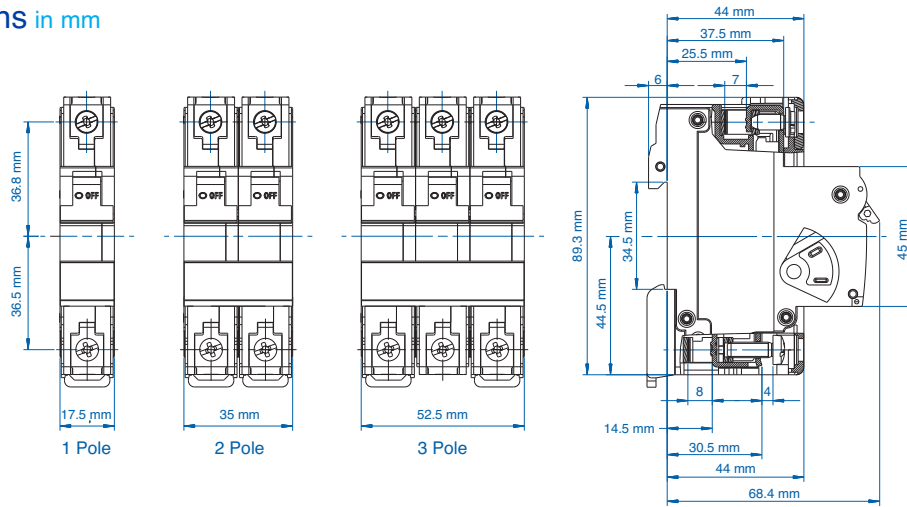

Application Overview

| Trip-Characteristics* | | | | Applications | | | | | | | | |
|--------------------------------|-----------------|-----------------------|--------------------|---|-------------------------------------|-------------------------|-------------------|------------------------|------------------|--|--|--|
| Characteristic Trip Boundaries | | | | Lighting Wiring Protection Control Circuits | Business Equipment Appliances | Control Transformers | Power Supplies | General Electronics | Reactive Load | | | |
| Thermal Trip | Magnetic Trip | | | | | | | | | | | |
| Must not Trip > 100ms | Must trip < 1hr | Must not Trip > 100ms | Must trip at 100ms | | | | | | | | | |
| B-Characteristics | | | | | | | | | | | | |
| 1. 13xR | 1. 45xR | 3xRC | 5xRC | | | | | | | | | |
| C-Characteristics | | | | | | | | | | | | |
| 1. 1xRC | 1. 4xRC | 5xRC | 10xRC | | | | | | | | | |
| D-Characteristics | | | | | | | | | | | | |
| 1. 1xRC | 1. 4xRC | 10xRC | 20xRC | | | | | | | | | |

*The value of characteristic is shown directly beneath its corresponding heading.



Warning!

This information should only be used as a selection guide. Miniature Circuit Breaker/Supplementary Protector in an application with a trip characteristic always requires prototype testing! It is the responsibility of the circuit design engineer to select the appropriate Miniature Circuit Breaker/Supplementary Protector for his specific application.

UL 489

UL 508

UL 1077

UL 1077
Equipment Breakers

Earth Leakage
Circuit Breakers

ANNEX

DLS7 Series B-Trip Characteristic

Application Examples:

Business equipment, wiring protection, lighting, appliances, control circuits, some motors and some electronic applications. Relatively long thermal trip delay but low magnetic trip point.



One Pole



Standard Pack: 12

Weight:

0.3A - 32A

1.75kg (3.86 lb.)

40A - 63A

2.07kg (4.56 lb.)

| Rated Current | Type/ Cat. No. | Rated Voltage |
|---------------|-------------------|---------------|
| 0.5A | 1B05UR | 277V AC |
| 1.0A | 1B1UR | 277V AC |
| 2.0A | 1B2UR | 277V AC |
| 3.0A | 1B3UR | 277V AC |
| 4.0A | 1B4UR | 277V AC |
| 5.0A | 1B5UR | 277V AC |
| 6.0A | 1B6UR | 277V AC |
| 8.0A | 1B8UR | 277V AC |
| 10A | 1B10UR | 277V AC |
| 12A | 1B12UR | 277V AC |
| 13A | 1B13UR | 277V AC |
| 15A | 1B15UR | 277V AC |
| 16A | 1B16UR | 277V AC |
| 20A | 1B20UR | 277V AC |
| 25A | 1B25UR | 277V AC |
| 30A | 1B30UR | 277V AC |
| 32A | 1B32UR | 277V AC |
| 40A | 1B40UR | 277V AC |
| 50A | 1B50UR | 277V AC |
| 60A | 1B60UR | 277V AC |
| 63A* | 1B63UR | 277V AC |

Three Pole



Standard Pack: 4

Weight:

0.3A - 32A

1.75kg (3.86 lb.)

40A - 63A

2.07kg (4.56 lb.)

| Rated Current | Type/ Cat. No. | Rated Voltage |
|---------------|-------------------|---------------|
| 0.5A | 3B05UR | 480Y/277V AC |
| 1.0A | 3B1UR | 480Y/277V AC |
| 2.0A | 3B2UR | 480Y/277V AC |
| 3.0A | 3B3UR | 480Y/277V AC |
| 4.0A | 3B4UR | 480Y/277V AC |
| 5.0A | 3B5UR | 480Y/277V AC |
| 6.0A | 3B6UR | 480Y/277V AC |
| 8.0A | 3B8UR | 480Y/277V AC |
| 10A | 3B10UR | 480Y/277V AC |
| 12A | 3B12UR | 480Y/277V AC |
| 13A | 3B13UR | 480Y/277V AC |
| 15A | 3B15UR | 480Y/277V AC |
| 16A | 3B16UR | 480Y/277V AC |
| 20A | 3B20UR | 480Y/277V AC |
| 25A | 3B25UR | 480Y/277V AC |
| 30A | 3B30UR | 480Y/277V AC |
| 32A | 3B32UR | 480Y/277V AC |
| 40A | 3B40UR | 480Y/277V AC |
| 50A | 3B50UR | 480Y/277V AC |
| 60A | 3B60UR | 480Y/277V AC |
| 63A* | 3B63UR | 480Y/277V AC |

Two Pole



Standard Pack: 6

Weight:

0.3A - 32A

1.75kg (3.86 lb.)

40A - 63A

2.07kg (4.56 lb.)

| Rated Current | Type/ Cat. No. | Rated Voltage |
|---------------|-------------------|---------------|
| 0.5A | 2B05UR | 480Y/277V AC |
| 1.0A | 2B1UR | 480Y/277V AC |
| 2.0A | 2B2UR | 480Y/277V AC |
| 3.0A | 2B3UR | 480Y/277V AC |
| 4.0A | 2B4UR | 480Y/277V AC |
| 5.0A | 2B5UR | 480Y/277V AC |
| 6.0A | 2B6UR | 480Y/277V AC |
| 8.0A | 2B8UR | 480Y/277V AC |
| 10A | 2B10UR | 480Y/277V AC |
| 12A | 2B12UR | 480Y/277V AC |
| 13A | 2B13UR | 480Y/277V AC |
| 15A | 2B15UR | 480Y/277V AC |
| 16A | 2B16UR | 480Y/277V AC |
| 20A | 2B20UR | 480Y/277V AC |
| 25A | 2B25UR | 480Y/277V AC |
| 30A | 2B30UR | 480Y/277V AC |
| 32A | 2B32UR | 480Y/277V AC |
| 40A | 2B40UR | 480Y/277V AC |
| 50A | 2B50UR | 480Y/277V AC |
| 60A | 2B60UR | 480Y/277V AC |
| 63A* | 2B63UR | 480Y/277V AC |

Add-on Neutral Pole



| Rated Current | Type/ Cat. No. | Rated Voltage |
|---------------|-------------------|---------------|
| 0.3-63A | N63UM | 480/277V AC |

Standard Pack: 6

Weight:

0.775kg (1.71)

*63A is not UL Recognized.

DLS7 Series C-Trip Characteristic

Application Examples:

Low inrush motors, lighting, wiring protection, appliances, business equipment, and control circuit applications. Relatively long thermal trip delay and medium magnetic trip point.



Standard Pack: 12
Weight:
0.3A - 32A
1.75kg (3.86 lb.)
40A - 63A
2.07kg (4.56 lb.)

One Pole

| Rated Current | Type/ Cat. No. | Rated Voltage |
|---------------|-------------------|---------------|
| 0.5A | 1C05UR | 277V AC |
| 1.0A | 1C1UR | 277V AC |
| 2.0A | 1C2UR | 277V AC |
| 3.0A | 1C3UR | 277V AC |
| 4.0A | 1C4UR | 277V AC |
| 5.0A | 1C5UR | 277V AC |
| 6.0A | 1C6UR | 277V AC |
| 8.0A | 1C8UR | 277V AC |
| 10A | 1C10UR | 277V AC |
| 12A | 1C12UR | 277V AC |
| 13A | 1C13UR | 277V AC |
| 15A | 1C15UR | 277V AC |
| 16A | 1C16UR | 277V AC |
| 20A | 1C20UR | 277V AC |
| 25A | 1C25UR | 277V AC |
| 30A | 1C30UR | 277V AC |
| 32A | 1C32UR | 277V AC |
| 40A | 1C40UR | 277V AC |
| 50A | 1C50UR | 277V AC |
| 60A | 1C60UR | 277V AC |
| 63A* | 1C63UR | 277V AC |



Standard Pack: 4
Weight:
0.3A - 32A
1.75kg (3.86 lb.)
40A - 63A
2.07kg (4.56 lb.)

Three Pole

| Rated Current | Type/ Cat. No. | Rated Voltage |
|---------------|-------------------|---------------|
| 0.5A | 3C05UR | 480Y/277V AC |
| 1.0A | 3C1UR | 480Y/277V AC |
| 2.0A | 3C2UR | 480Y/277V AC |
| 3.0A | 3C3UR | 480Y/277V AC |
| 4.0A | 3C4UR | 480Y/277V AC |
| 5.0A | 3C5UR | 480Y/277V AC |
| 6.0A | 3C6UR | 480Y/277V AC |
| 8.0A | 3C8UR | 480Y/277V AC |
| 10A | 3C10UR | 480Y/277V AC |
| 12A | 3C12UR | 480Y/277V AC |
| 13A | 3C13UR | 480Y/277V AC |
| 15A | 3C15UR | 480Y/277V AC |
| 16A | 3C16UR | 480Y/277V AC |
| 20A | 3C20UR | 480Y/277V AC |
| 25A | 3C25UR | 480Y/277V AC |
| 30A | 3C30UR | 480Y/277V AC |
| 32A | 3C32UR | 480Y/277V AC |
| 40A | 3C40UR | 480Y/277V AC |
| 50A | 3C50UR | 480Y/277V AC |
| 60A | 3C60UR | 480Y/277V AC |
| 63A* | 3C63UR | 480Y/277V AC |



Standard Pack: 6
Weight:
0.3A - 32A
1.75kg (3.86 lb.)
40A - 63A
2.07kg (4.56 lb.)

Two Pole

| Rated Current | Type/ Cat. No. | Rated Voltage |
|---------------|-------------------|---------------|
| 0.5A | 2C05UR | 480Y/277V AC |
| 1.0A | 2C1UR | 480Y/277V AC |
| 2.0A | 2C2UR | 480Y/277V AC |
| 3.0A | 2C3UR | 480Y/277V AC |
| 4.0A | 2C4UR | 480Y/277V AC |
| 5.0A | 2C5UR | 480Y/277V AC |
| 6.0A | 2C6UR | 480Y/277V AC |
| 8.0A | 2C8UR | 480Y/277V AC |
| 10A | 2C10UR | 480Y/277V AC |
| 12A | 2C12UR | 480Y/277V AC |
| 13A | 2C13UR | 480Y/277V AC |
| 15A | 2C15UR | 480Y/277V AC |
| 16A | 2C16UR | 480Y/277V AC |
| 20A | 2C20UR | 480Y/277V AC |
| 25A | 2C25UR | 480Y/277V AC |
| 30A | 2C30UR | 480Y/277V AC |
| 32A | 2C32UR | 480Y/277V AC |
| 40A | 2C40UR | 480Y/277V AC |
| 50A | 2C50UR | 480Y/277V AC |
| 60A | 2C60UR | 480Y/277V AC |
| 63A* | 2C63UR | 480Y/277V AC |



Add-on Neutral Pole

| Rated Current | Type/ Cat. No. | Rated Voltage |
|---------------|-------------------|---------------|
| 0.3-63A | N63UM | 480/277V AC |

Standard Pack: 6
Weight:
0.775kg (1.71)

*63A is not UL Recognized.

UL 489

UL 508

UL 1077

UL 1077
Equipment Breakers

Earth Leakage
Circuit Breakers

ANNEX

DLS7 Series

D-Trip

Characteristic

Application Examples:

Control transformers, power supplies, reactive loads. Relatively long thermal trip delay and very high magnetic trip point.



Standard Pack: 12

Weight:

0.3A - 32A

1.75kg (3.86 lb.)

40A - 63A

2.07kg (4.56 lb.)

One Pole

| Rated Current | Type/ Cat. No. | Rated Voltage |
|---------------|-------------------|---------------|
| 0.5A | 1D05UR | 277V AC |
| 1.0A | 1D1UR | 277V AC |
| 2.0A | 1D2UR | 277V AC |
| 3.0A | 1D3UR | 277V AC |
| 4.0A | 1D4UR | 277V AC |
| 5.0A | 1D5UR | 277V AC |
| 6.0A | 1D6UR | 277V AC |
| 8.0A | 1D8UR | 277V AC |
| 10A | 1D10UR | 277V AC |
| 12A | 1D12UR | 277V AC |
| 13A | 1D13UR | 277V AC |
| 15A | 1D15UR | 277V AC |
| 16A | 1D16UR | 277V AC |
| 20A | 1D20UR | 277V AC |
| 25A | 1D25UR | 277V AC |
| 30A | 1D30UR | 277V AC |
| 32A | 1D32UR | 277V AC |
| 40A | 1D40UR | 277V AC |
| 50A | 1D50UR | 277V AC |
| 60A | 1D60UR | 277V AC |
| 63A* | 1D63UR | 277V AC |



Standard Pack: 4

Weight:

0.3A - 32A

1.75kg (3.86 lb.)

40A - 63A

2.07kg (4.56 lb.)

Three Pole

| Rated Current | Type/ Cat. No. | Rated Voltage |
|---------------|-------------------|---------------|
| 0.5A | 3D05UR | 480Y/277V AC |
| 1.0A | 3D1UR | 480Y/277V AC |
| 2.0A | 3D2UR | 480Y/277V AC |
| 3.0A | 3D3UR | 480Y/277V AC |
| 4.0A | 3D4UR | 480Y/277V AC |
| 5.0A | 3D5UR | 480Y/277V AC |
| 6.0A | 3D6UR | 480Y/277V AC |
| 8.0A | 3D8UR | 480Y/277V AC |
| 10A | 3D10UR | 480Y/277V AC |
| 12A | 3D12UR | 480Y/277V AC |
| 13A | 3D13UR | 480Y/277V AC |
| 15A | 3D15UR | 480Y/277V AC |
| 16A | 3D16UR | 480Y/277V AC |
| 20A | 3D20UR | 480Y/277V AC |
| 25A | 3D25UR | 480Y/277V AC |
| 30A | 3D30UR | 480Y/277V AC |
| 32A | 3D32UR | 480Y/277V AC |
| 40A | 3D40UR | 480Y/277V AC |
| 50A | 3D50UR | 480Y/277V AC |
| 60A | 3D60UR | 480Y/277V AC |
| 63A* | 3D63UR | 480Y/277V AC |



Standard Pack: 6

Weight:

0.3A - 32A

1.75kg (3.86 lb.)

40A - 63A

2.07kg (4.56 lb.)

Two Pole

| Rated Current | Type/ Cat. No. | Rated Voltage |
|---------------|-------------------|---------------|
| 0.5A | 2D05UR | 480Y/277V AC |
| 1.0A | 2D1UR | 480Y/277V AC |
| 2.0A | 2D2UR | 480Y/277V AC |
| 3.0A | 2D3UR | 480Y/277V AC |
| 4.0A | 2D4UR | 480Y/277V AC |
| 5.0A | 2D5UR | 480Y/277V AC |
| 6.0A | 2D6UR | 480Y/277V AC |
| 8.0A | 2D8UR | 480Y/277V AC |
| 10A | 2D10UR | 480Y/277V AC |
| 12A | 2D12UR | 480Y/277V AC |
| 13A | 2D13UR | 480Y/277V AC |
| 15A | 2D15UR | 480Y/277V AC |
| 16A | 2D16UR | 480Y/277V AC |
| 20A | 2D20UR | 480Y/277V AC |
| 25A | 2D25UR | 480Y/277V AC |
| 30A | 2D30UR | 480Y/277V AC |
| 32A | 2D32UR | 480Y/277V AC |
| 40A | 2D40UR | 480Y/277V AC |
| 50A | 2D50UR | 480Y/277V AC |
| 60A | 2D60UR | 480Y/277V AC |
| 63A* | 2D63UR | 480Y/277V AC |



Add-on Neutral Pole

| Rated Current | Type/ Cat. No. | Rated Voltage |
|---------------|-------------------|---------------|
| 0.3-63A | N63UM | 480/277V AC |

Standard Pack: 6

Weight:

0.775kg (1.71)

*63A is not UL Recognized.

DLS7 Series Accessories

For mounting instructions please refer to page 61.



E137938

Auxiliary Contact, Alarm Switch



| Type/ Cat No. | Description | Contacts Type | Std Pk |
|---------------|-----------------------------------|--------------------|--------|
| H10UM | 1 Auxiliary Contact | 1NO | 6 |
| H11UM | 2 Auxiliary Contacts | 1NO + 1NC | 6 |
| H12UM | 3 Auxiliary Contacts | 1NO + 2NC | 6 |
| H21UM | 3 Auxiliary Contacts | 2NO + 1NC | 6 |
| HLS11M* | 1 Auxiliary/ 1 Signal Contacts | 1CO + 1CO (Signal) | 6 |

| | |
|-----------------------------------|---|
| Rated Operating Currents | 10A@240V AC 3A@110V DC 1A@220V DC |
| Minimum Contact Load | 1mA @ 24V DC |
| Torque | max. 0.8Nm (7 lb.in) |
| Wire Range: | |
| Single Wire | 1.0mm ² - 2.5mm ² (18-14 AWG) |
| Stranded Wire | 1.0mm ² - 1.5mm ² (18-16 AWG) |
| Stranded Wire with Ferrule | 1.0mm ² - 1.5mm ² (18-16 AWG) |

Shunt Trip



| Type/ Cat No. | Rated Voltage U _N | Max. Operating Current @ U _N | Std Pk |
|---------------|-------------------------------|---|--------|
| FA12UM | 12V AC/DC | 1.3A | 5 |
| FA24UM | 24V AC/DC | 0.6A | 5 |
| FA48UM | 48 - 72V AC/DC | 0.2A | 5 |
| FA110UM | 110 - 240 V AC/DC, 277V AC | 0.25A @ 110V 0.5A @ 240V 0.58A @ 277V | 5 |

Neutral Pole



| Type/ Cat No. | Rated Current I _N | Rated Voltage U _N | Std Pk |
|---------------|------------------------------|------------------------------|--------|
| N63UM | 0.3 - 63A | 480Y/277V AC | 6 |

Touch Protection Caps

to cover the terminal screw holes on the switching devices, neutral Poles and shunt trips for increased touch protection.



| Type/ Cat No. | Std Pk | Type/ Cat No. | Std Pk |
|---------------|--------|---------------|--------|
| BS.UL | 100 | 15.960 | 1 |

Cooling Spacer



Mounting Screw 34mm

to connect the auxiliary contact and shunt trip or neutral Pole to the circuit breaker.



| Type/ Cat No. | Std Pk | Type/ Cat No. | Std Pk |
|---------------|--------|---------------|--------|
| E983419 | 10 | EASS | 10 |

Lock-out Adapter**



** UR series can also be locked in the on and off position by simply using a common lead or meter seal, which gets fed through the hole in the handle and a corresponding hole in the housing.

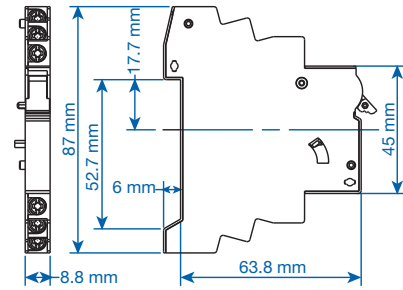

Dimensions HxxUM.

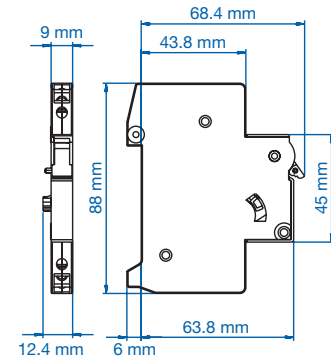

Dimensions HLS11M.

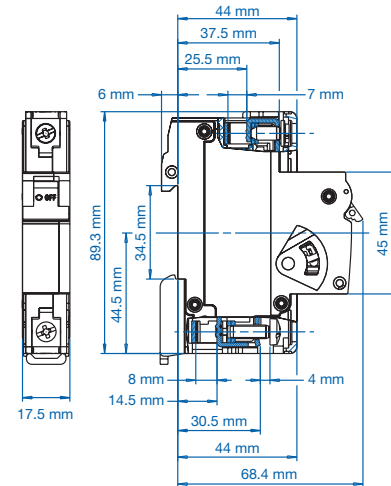

Dimensions N63UM, FAppUM.

UL 489

UL 508

UL 1077

UL 1077
Equipment Breakers

Earth Leakage
Circuit Breakers

ANNEX

DLS7 Series Trip Curves

B Trip Curve

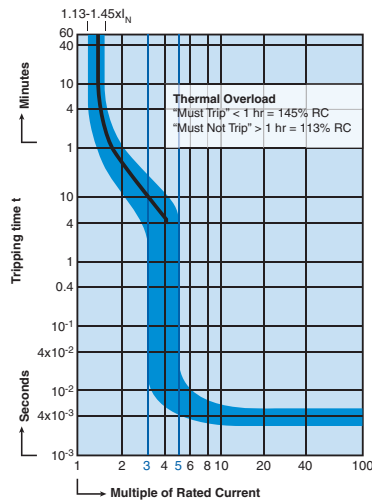

0.5A Through 10A Rated Current

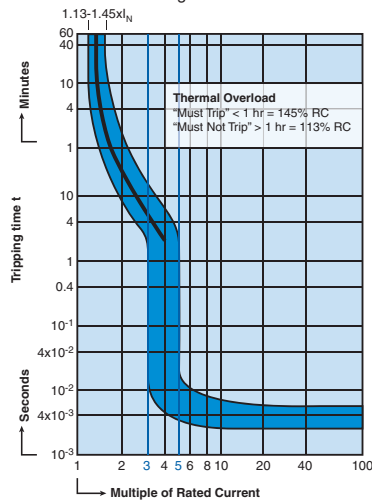

12A Through 63A Rated Current

“B” Magnetic Trip Parameters

Rated current 0.5A to 63A.

1. Hold for a minimum of 100ms at surge of 3 times rated current.
2. Trip in under 100ms at 5 times rated current.

C Trip Curve

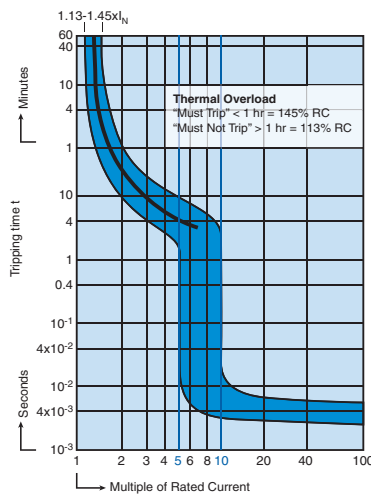

0.5A Through 10A Rated Current

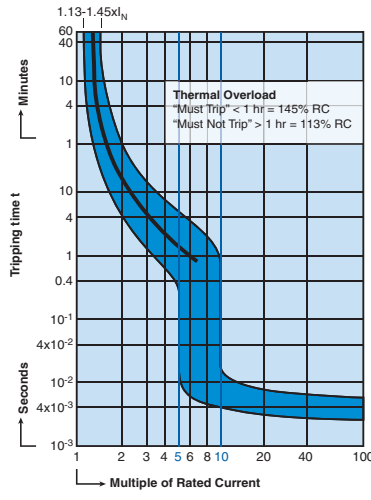

12A Through 63A Rated Current

“C” Magnetic Trip Parameters

Rated current 0.5A to 63A.

1. Hold for a minimum of 100ms at surge of 5 times rated current.
2. Trip in under 100ms at 10 times rated current.

D Trip Curve

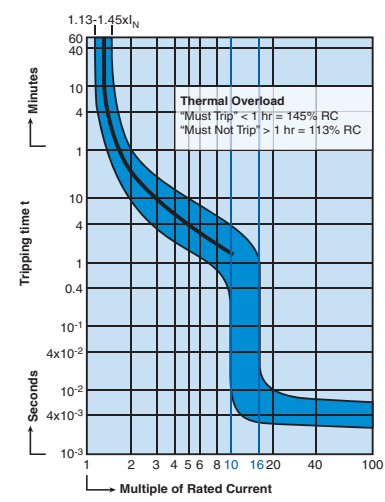

0.5A Through 10A Rated Current

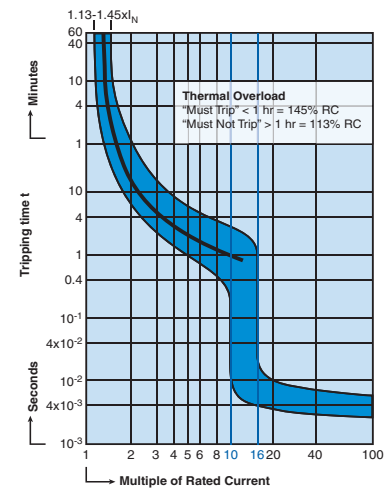

12A Through 63A Rated Current

“D” Magnetic Trip Parameters

Rated current 0.5A to 63A.

1. Hold for a minimum of 100ms at surge of 10 times rated current.
2. Trip in under 100ms at 16 times rated current.

UR Series Internal Resistance

| Rated Current (A) | Trip Characteristic | | |
|----------------------|---------------------|------------|------------|
| | B (Ohm) | C (Ohm) | D (Ohm) |
| 0.5 | 8.0400 | 6.8540 | 6.0009 |
| 1.0 | 1.7000 | 1.7000 | 1.7560 |
| 2.0 | 0.4190 | 0.4190 | 0.4190 |
| 3.0 | 0.2020 | 0.2020 | 0.2020 |
| 4.0 | 0.1090 | 0.1090 | 0.1090 |
| 5.0 | 0.0654 | 0.0654 | 0.0654 |
| 6.0 | 0.0528 | 0.0528 | 0.0491 |
| 8.0 | 0.0278 | 0.0278 | 0.0240 |
| 10 | 0.0216 | 0.0216 | 0.0187 |
| 12/ 13 | 0.0113 | 0.0084 | 0.0085 |
| 15/ 16 | 0.0085 | 0.0085 | 0.0076 |
| 20 | 0.0067 | 0.0067 | 0.0064 |
| 25 | 0.0050 | 0.0050 | 0.0041 |
| 30/ 32 | 0.0032 | 0.0032 | 0.0027 |
| 40 | 0.0025 | 0.0025 | 0.0022 |
| 50 | 0.0019 | 0.0019 | 0.0018 |
| 60/ 63* | 0.0018 | 0.0018 | 0.0017 |

Temperature Correction Curve (DLS7/8/9 series)

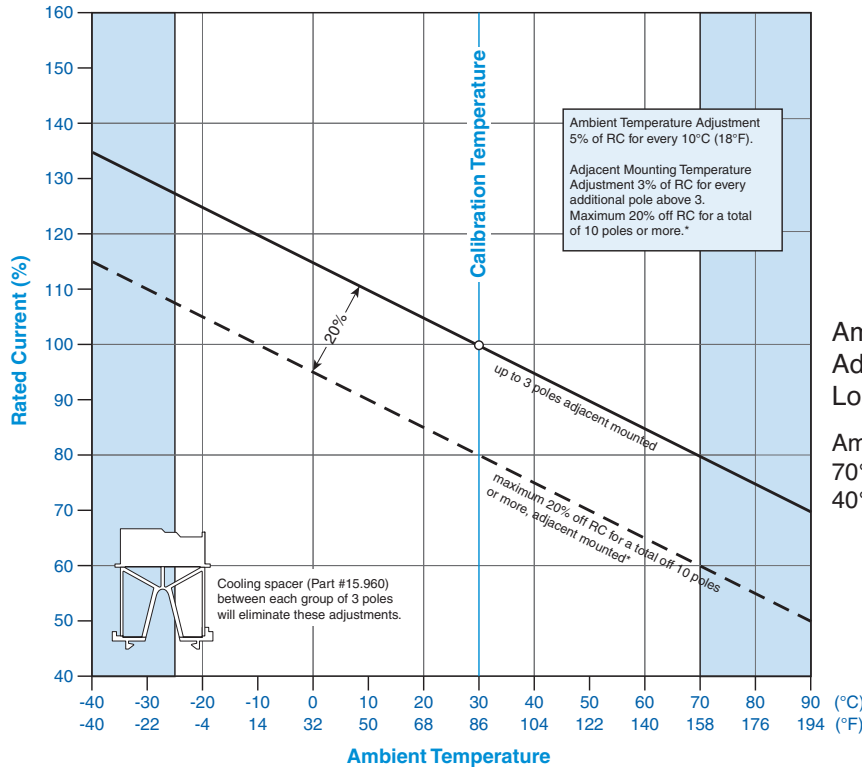

UL 489

UL 508

UL 1077

Accessory Mounting Instructions (DLS7/8/9 series)

Neutral / Shunt Trip + Auxiliary Contact

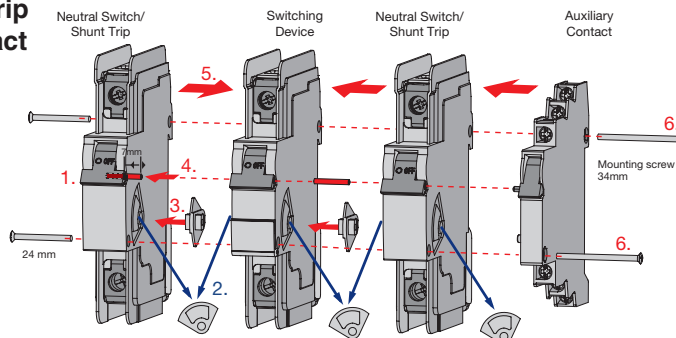

Neutral Poles N63UM, N32UL, N63UL or Shunt Trips FA..UM, FA..UL can be mounted on the right or left side of the circuit protection device.

1. Turn handle to off position.
2. Remove gray cover from the circuit protection device and accessory.
3. Insert linkage component between circuit protection device and neutral pole (N63UM, N32UL, N63UL) or shunt trip (FA..UM, FA..UL).
4. Insert connecting pin into handle.
5. Assemble circuit protection device and neutral pole (N63UM, N32UL, N63UL) or shunt trip (FA..UM, FL..UL).
6. The auxiliary contact (H..UM, H..UL) can also be mounted on the right side by using a different screw (E983419; see accessory pages 14, 32 or 41).

After final assembly check operation by moving the handle to the ON/OFF position several times.

Auxiliary Contact

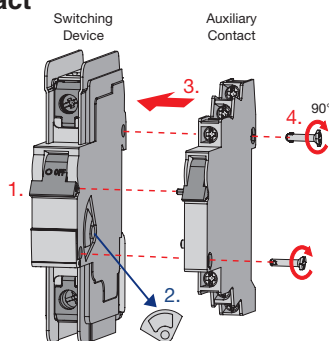

Auxiliary contact can be mounted on the right side of the circuit protection device only.

1. Turn handles to OFF position.
2. Remove gray cover from switching device.
3. Combine circuit protection device and auxiliary contact (H...UM, H...UL).
4. Insert mounting screws and connect the two devices by turning the screws 90° clockwise.

After final assembly check operation by moving the handle to the ON/OFF position several times.

UL 1077
Equipment Breakers

Earth Leakage
Circuit Breakers

ANNEX

DFS Series RCCB Earth Leakage Circuit Breakers

RCCB Series compact Earth Leakage Circuit Breakers detect and interrupt earth (ground) faults. They are VDE approved for the European system of protecting people, animals, equipment and property from dangerous line-to-ground and shock hazard currents.

US applications include ground-fault protection of equipment (GFPE) using the 10mA and 30mA fault current ratings, especially when high distributed capacitance or other leakages cause excessive nuisance trips at lower fault currents. Applications for the 300mA and 500mA ratings are equipment protection and fire prevention, limiting the energy of a fault to less than the minimum ignition energy for many materials.

Type Designation

DFS (a) (b) (c)

(a): 11 = 16A, 12 = 25A, 13 = 40A,
14 = 63A, 15 = 80A, 16 = 100A,
17 = 125A

(b): 2 = 10mA, 4 = 30mA,
6 = 300mA, 7 = 500mA

(c): 601 = 2 pole, 911 = 4 pole



DFS2



DFS4



| Maximum Rated Line Current | Fault Trip Current | Cat. No. | Supersedes | Fault Trip Current | Cat. No. | Supersedes |
|----------------------------|--------------------|-----------------|------------|--------------------|-----------------|------------|
| 16A | 10mA | 09112601 | RP2101 | | | |
| 25A | 30mA | 09124601 | RP2203 | 30mA | 09124911 | RP4203 |
| 25A | 300mA | 09126601 | RP2230 | 300mA | 09126911 | RP4230 |
| 25A | | | | 500mA | 09127911 | RP4250 |
| 40A | 30mA | 09134601 | RP2303 | 30mA | 09134911 | RP4303 |
| 40A | 300mA | 09136601 | RP2330 | 300mA | 09136911 | RP4330 |
| 40A | | | | 500mA | 09137911 | RP4350 |
| 63A | 30mA | 09144601 | RP2403 | 30mA | 09144911 | RP4403 |
| 63A | 300mA | 09146601 | RP2430 | 300mA | 09146911 | RP4430 |
| 63A | 500mA | | | 500mA | 09147911 | RP4450 |
| 80A | | | | 30mA | 09154911 | RP4503 |
| 80A | | | | 300mA | 09156911 | RP4530 |
| 80A | | | | 500mA | 09157911 | RP4550 |
| 100A | | | | 30mA | 09164911 | RP4603 |
| 100A | | | | 300mA | 09166911 | RP4630 |
| 100A | | | | 500mA | 09167911 | RP4650 |
| 125A | | | | 30mA | 09174911 | RP4703 |
| 125A | | | | 300mA | 09176911 | RP4730 |
| 125A | | | | 500mA | 09177911 | RP4750 |

Stock items are shown in BOLD.

| | | |
|---|---|----------------------------------|
| Voltage Rating (maximum) | 230V AC, 50Hz | 400Y/230V AC, 50Hz |
| Min Operating Voltage Bank of Test Circuit | 150V | 200V |
| Short Circuit Withstand Rating | No back-up fuse: Rated current (RC) 16/25/40A: 500A; RC 63/80A: 800A; RC 100A: 1000A; RC 125A-1250A. With back-up fuse: 10kA; Size of fuse: (2 pole version): RC 25/40/63: 100A; (4 pole version): RC 25/40/63A: 100A; RC 80/100/125A: 125A | |
| Fault Trip Current Calibration | DFS trips are calibrated at less than fault trip current for ensured safety (Typical trip range between 66.6-83.3% fault trip current, e.g., typical trip at 20-25mA for fault RC of 30mA) | |
| Typical Life | Fully functional after 5,000 operations to DIN/VDE 0664T10, IEC 61008-1 and 2000 additional fault current trips. | |
| Standard Pack and Weight | 1/230g (0.6 lb.) | 1/420-460g (0.9 lb.-1.0 lb.) |
| Terminal Size Acceptability | 1.5-50mm ² (16-1 AWG) | 1.5-50mm ² (16-1 AWG) |
| Terminal Torque | 3Nm (26.5 lb.in.) | 3Nm (26.5 lb.in.) |

Circuit Diagram

a For 2-Phase applications, terminal 5 and 6 (next to Neutral terminals) must be connected to one phase for the test circuit to be operable.

b For voltage systems without a neutral conductor. Please use jumper from "1" or "3" to top "N" terminal. This will assure proper functioning of the "test" circuit.

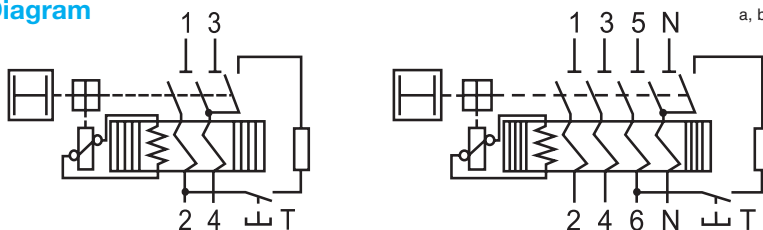

DHI11 - Auxiliary Switches / Error Signal Switch

| Contact Rating | Wire Size | Torque | Cat. No. | Supersedes | Circuit Diagram |
|---|----------------------------------|-------------------------|--------------|------------|-----------------|
| 6A / 230V AC 1A / 110V DC | 1-1.5mm ² (16 AWG) | max. 0.8Nm (7lb.in.) | DHI11 | RH11 | |
| Std. Pk.: 1 Unit Weight: 45 grams (0.12 lb.) Width: 9mm (.354in.) | | | | | |

Note: If the power system has a marked conductor, it must connect through the DFS and not be grounded at any point downstream.



Dimensions in mm

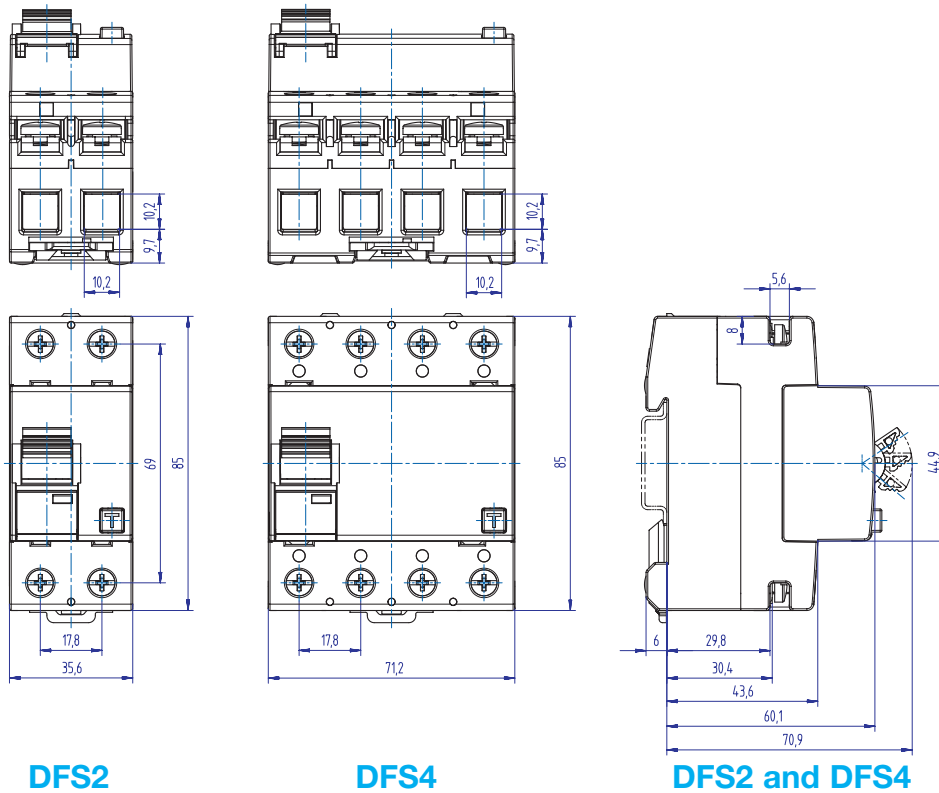

DFS2

DFS4

DFS2 and DFS4

Temperature Range Environmental Information marked with “Snowflake” approval for -25°C to 40°C (-13°F to 104°F) ambient temperature. (Temperature effect on RC: for every 10°C temperature rise above 40°C decrease RC by 7%.)

Fluctuating Climate Conditions According to IEC 60068-2-30: heat (25°C~55°C), relative humidity (93%~95%)

Electrical Shock Protection Uninsulated electrically live parts within 30mm of the operating handle are “finger safe” (terminal screw heads) and uninsulated live parts within 100mm of the operating handle are “back-of-hand safe” (terminals).

Impact/Shock Protection 20g with impact force half-cycle sinusoidal and 20ms duration, 18 impacts total with 6 on each principal axis (3 impacts each face). DFS is DIN Rail mounted during the test, and electrically loaded with 25% of Fault RC. Successful testing required no trip during the test, no damage and no loosened parts.

Vibration/Seismic Resistance 5g, at frequency of ≤80Hz, applied for 30 minutes along each of the three principal axes, plus 5 minutes of application at every established critical resonant frequency. DFS is DIN Rail mounted during the test, and loaded with 25% Fault RC. To pass, the DFS did not trip at 25% Fault RC, but did trip between each of the principal axis tests when the fault current was raised to 125% Fault RC, and there was no damage and no loosened parts. Suitable for machinery and mobile vehicle applications.

Protection Class IP20; higher protection Class is dependent on housing.

Non-Sinusoidal Fault The DFS is tested and approval stamped for tripping sensitivity to non-sinusoidal fault currents, which become zero or almost zero within one cycle of the line frequency. Waveforms and allowed trip-current ranges are as follows:

1. AC Sinusoidal Fault - 0.5-1.0 times Fault RC
- 2a. Pulsating DC Fault;
Positive and Negative Half-Waves - 0.35-1.4 times Fault RC
- 2b. Phased Half-Wave, 90° - 0.25-1.4 times Fault RC
Phased Half-Wave, 135° - 0.11-1.4 times Fault RC
3. Pulsating DC on 6mA
DC (continuous) Base - Max. 1.4 times Fault RC + 6mA

Insulation Category At VDE rated voltage, suitable for Class C environments with relatively high dust and moisture levels and little HVAC control, e.g., industrial, commercial, agricultural; on machine tools, hoists, warehouse equipment, etc.; in boiler rooms, unheated storage, covered shipping/receiving, open workshops, etc.



Altech Search

- Home
- Stock Check
- Distributors
- Information
- News
- Contact
- Rep/Disti Login
- Altech Mexico

WEB TOOLS

- Altech Videos
- Product Crossings
- Request for Quote
- Sample Request
- Catalog Request
- eBook Catalog

PRODUCT MENU

- ATEX Products
- Circuit Protection / Control
- Connectors
- Enclosures
- European Spare Parts
- Digital Panel Meters
- Foot Switches
- Interface Modules
- Panel Accessories
- Power Supplies
- Power Semi-Conductors
- Programmable Controllers
- Push Buttons & Pilot Lights
- Relays
- Sensors
- Safety Switches & Enclosures
- Solid State Relays
- Terminal Blocks
- Test & Measurement
- Power Lights

New Products and Promotions

AS SHORT AS **2** Week Turn Around

CUSTOM ASSEMBLY and Valued Added Services

- Imprinting
- Relay Modules
- Light Assemblies
- Interface Modules
- Component Carrier Modules
- Foot Switch Assemblies
- DIN Rail Assemblies
- Enclosure Milling

Click for your local
ALTECH REPRESENTATIVE

Serving the Automation & Control Industry
Since 1984

CIRCUIT PROTECTION



Circuit Protection Devices



Busbar & Power Distribution



Contactors, Overload Relays, Manual Motor Starters



Motor Disconnect Switches



European Fuses & Holders

CONNECTORS



Pin & Sleeve Devices



Receptacles



Industrial Rectangular Connectors



Industrial & ATEX Enclosures



DIN Enclosures

FOOT SWITCHES



Industrial



Medical

MODULES & RELAYS



Interface Modules



Safety Relays



Industrial & Slimline Relays

Altech Corporation
35 Royal Road
Flemington, NJ 08822-6000
Phone (908) 806-9400
Fax (908) 806-9490
www.altechcorp.com